



A new variety of local realism explains a Bell test experiment: the Theory of Elementary Waves (TEW) with no hidden variables

Jeffrey H. Boyd

Retired, 57 Woods Road, Bethany, CT 06524 USA

jeffreyhboyd@gmail.com

ABSTRACT

In a recent article on the Theory of Elementary Waves (TEW) (see “TEW eliminates Wave Particle Duality” in *JAP*, February 2015), the most controversial aspect was the claim that TEW provides a local realistic explanation of the Alain Aspect 1982 experiment. That claim was not proved. This article fills in that gap by providing a local realistic explanation of a Bell test experiment published in 1998 by Weihs, Jennewein, Simon, et al. Advanced TEW uses no hidden variables, and therefore does not fall under the jurisdiction of Bell’s theorem. It rejects wave particle duality. It violates the Bell inequalities, yet is local and realistic. Particles follow a bi-ray, which is composed of two elementary rays, traveling at the speed of light in opposite directions, coaxially, conveying no energy. As was the case with the previous article, the main obstacle to credibility is that these assumptions sound incredible. It is wise sometimes to tolerate ridiculous ideas, lest we fail to recognize a paradigm shift when one comes along. Another obstacle to credibility is the multitude of unanswered questions. A truly fruitful theory raises more questions than it answers, by a ratio of 100 to 1. TEW fulfills that definition of fruitfulness.

Indexing terms/Keywords

Bell test experiment, Alain Aspect, Theory of Elementary Waves, TEW, entanglement, nonlocality, Gregor Weihs, Thomas Jennewein, Christoph Simon

Academic Discipline And Sub-Disciplines

Physics, Quantum Physics, Foundations of quantum mechanics

SUBJECT CLASSIFICATION

Library of Congress Classification #'s for Quantum Theory are from QC173.96 to QC174.52

for example: QC173.96 Quantum Mechanics Foundations

TYPE (METHOD/APPROACH)

This article presents a local realistic explanation of a Bell test experiment, without any use of Einstein’s hidden variables. It is based on the advanced Theory of Elementary Waves (TEW): photons that appear to be “entangled” are both following the same bi-ray. A bi-ray is a pair of elementary rays traveling coaxially in opposite directions at the speed of light, conveying no energy. Starting only with the assumption that the Born rule is true, we show that the probability of Alice and Bob simultaneously seeing a photon is proportional to $\sin^2(\beta - \alpha)$. Previously Alice and Bob have at random rotated their polarizers to arbitrary angles α and β .

Council for Innovative Research

Peer Review Research Publishing System

Journal: JOURNAL OF ADVANCES IN PHYSICS

Vol.8, No.1

www.cirjap.com, japeditor@gmail.com



INTRODUCTION

An earlier article in this journal sketched the Theory of Elementary Waves (TEW),[1] a new perspective on the quantum world which strikes many readers as harebrained, which is the hallmark of a paradigm shift. Whenever there is a change in worldview, the new perspective appears so absurd as to be unworthy of discussion, from the viewpoint of the established worldview.

Of the various claims made about TEW in that previous article, the most controversial is that it is a local realistic theory that uses none of Einstein's hidden variables.[2] It was claimed that advanced TEW could explain Alain Aspect's 1982 Bell test experiment with delayed choice, and that TEW is the only form of local realism making such a claim.[3,4] It was alleged that TEW does not sneak through some loophole in Bell's theorem. Rather it lies outside the jurisdiction of Bell's theorem. Although that was the most controversial aspect of the previous article, it was not explored in depth. For example, the Aspect experiment was not described.

The article you are now reading fills that void by analyzing a Bell test experiment published in *Physical Review Letters* in 1998 by Weihs, Jennewein, Simon et. al. from the University of Innsbruck.[5] Those researchers carefully plugged up loopholes in the Bell test experiment theory to make sure there was no covert communication between Alice and Bob, separated by 400 meters and using different computers. We claim that advanced TEW can explain Gregor Weihs data with local realism.

Although TEW has all the characteristics of a harebrained idea, the same can be said of the Weihs article, which concludes by endorsing David Mermin's proposal that the moon only exists when people look at it.[5] So what is so harebrained about the article you are now reading? The answer is that we introduce a new dingbat idea, whereas Weihs uses dingbat ideas that are familiar.

1. TEW is a local, realistic theory of the quantum world

It is easy to show that TEW is a local theory, but not that it is realistic. It is local as an undulatory picture of nature, where each point of a wave is connected to the adjoining point, not counting quantum discontinuities. In TEW there is no nonlocality: every effect has a local cause, which could of course be a field. Time never goes backwards.

To show that TEW is realistic, we have to define what we mean by "realistic." Our first approximate definition is that which makes sense to non-physicists. There are two ideas of QM that clearly violate realism: that a particle on the far side of the galaxy can instantaneously effect a particle here; and that the moon only exists when people look at it. TEW is more realistic than that.

However, TEW challenges ordinary people to view their world from a different perspective, before there could be rapprochement between the popular view and the TEW view of nature. Suppose you take a photograph with your cell phone. What happens? Most people would declare TEW absurd in claiming that elementary rays from the phone emanate forth, and photons followed those rays backwards.

In 1900 Einstein's ideas about time and space warping would have been classified as "unrealistic." Yet we speak of relativity as realistic today. Therefore as a second approximation of our definition of "realistic" needs to encompass how a non-physicist might view reality after changing worldviews.

At the time of Copernicus a heliocentric solar system would have been unrealistic by popular opinion. A century later it was realistic. TEW claims to have that third approximation to the definition of realism that Copernicus had, namely the unpopular kind, the kind that makes you a pariah. Any young person who is tempted to tread the TEW trail should make note of this warning. To follow this trail and to have a career in physics may not be compatible goals.

2. TEW is outside the jurisdiction of Bell's theorem

If you start with the assumption of wave particle duality, then your options for defining local realism are extremely limited. John Bell and his followers were trapped in that straightjacket.[6,7] The form of Bell's theorem used by Weihs is from Clauser, Horne, Shimony and Holt (CHSH).[8] Local realism is defined by CHSH as "a statistical correlation of $A(a)$ and $B(b)$. . . due to information carried by and localized within each particle." It is precisely that definition that is used by CHSH to develop Bell inequality. In the Weihs article the Bell inequality is defined as $|E(\alpha, \beta) - E(\alpha', \beta)| + |E(\alpha, \beta') + E(\alpha', \beta')| \leq 2$. We will not define "E" here. Data from the Weihs experiment show that the left side of this equation reaches a maximum of $2\sqrt{2} = 2.82$, which exceeds the boundary of 2. Therefore the data are incompatible with local realism as so defined.

However, what happens if you escape the straightjacket by rejecting wave particle duality? None of what CHSH said applies to TEW. The particles in TEW contain no internal information of interest. Each particle is following a ray or bi-ray, and it is those pathways which contain information that differs from one particle to the next. For example, consider a double slit experiment. If an electron is triggered it will follow the triggering elementary ray with a probability of one. At first it looks as if each electron is identical to the next. However once they pass through the double slit barrier we discover that they have been following divergent pathways. In introductory TEW every point of the target screen had emitted elementary rays before an electron is triggered. A multitude of elementary rays converging on the electron gun compete with one another, with the probability of winning proportional to the probability amplitude of the ray, squared. After an electron randomly chooses to follow one of the rays it does not deviate from that ray. No interference after electron emission has any influence. Thus the scatter on the target screen is caused by different elementary rays, not by any information embedded inside the electrons.

The TEW worldview is that we live in a universe where at every location and in every inertial frame there are zero energy rays of all frequencies and all polarizations traveling at the speed of light in all directions. If you make that assumption then it logically follows that every elementary ray has a partner: an identical ray traveling coaxially in the opposite direction. Advanced TEW focuses on such bi-rays. The proposal in this article is that a pair of photons that appear to be entangled in the Weihs experiment, are both following both prongs of the same bi-ray. The phenomena called “entanglement” are not because they are two parts of the same wave equation. The wave equation is a crude device used to quantify the effects of a bi-ray. It is not known how or why particles behave in that way, nor is it known how two such rays could be coherent. As with any productive theory, TEW raises more questions than it answers, by a ratio of 100 to 1, as we said earlier.

What starting assumptions do we make? We assume ONLY that the probability of each photon following a bi-ray is proportional to the probability amplitude of one ray, times the probability amplitude of its mate. They both have the same probability amplitude. This embodies the Born rule, where \mathbf{A} is the probability amplitude of one ray and $\mathbf{P} = |\mathbf{A}|^2$ is the probability that a photon will follow that bi-ray.

We propose in this article to show how that assumption alone can account for the following data: if Alice and Bob independently and randomly set their polarizers to any angles α and β respectively, then the probability of both Alice and Bob simultaneously seeing a photon is proportional to $\sin^2(\beta - \alpha)$. This is a famous outcome of Bell test experiments. But it is only one of 16 sinusoidal curves generated by the Weihs experiment. We will limit our discussion to $\sin^2(\beta - \alpha)$, and ignore the other 15 curves. If we succeed at this modest goal then we will have proved that advanced TEW is like QM, in that it violates the Bell inequality.

3. Using imagery as a style of mathematical thought

TEW is picturable, unlike QM. Much of our logic will arise from the Figures in this article. This is like mathematics in ancient Greece. When Archimedes developed calculus, the geometric diagrams were central to his reasoning. Omit the Figures and Archimedes would have had no calculus.

The top half of Figure 1 shows the photon source used by Weihs et al. An Argon-ion-laser (not shown) produces 400 mW of light, with wavelength 351 nm and is pumped into a beta barium borate (BBO) crystal. The crystal is shown as a yellow rectangle. The nature of this crystal is to split light into two polarized and mutually orthogonal beams, each with half the energy. In the top center of Figure 1 are two 702 nm photons, shown as circles, emerge on from the yellow rectangle. These are polarized H-V on the left, versus V+H on the right. The hands inside the circles are not clock hands. They indicate the polarization. These photons then enter fiberoptic cables, one on either side.

This picture is translated into TEW language in the bottom half of Figure 1. Elementary rays ψ_L and ψ_R enter from the left and right respectively. We show the vertical and horizontal projections of these two ray, corresponding to the H-V polarization of the left photon in the upper diagram, and the V+H polarization of the right photon. The idea behind introductory TEW is that a photon can only travel from its source to Alice on the left, if it is following an elementary ray ψ_L moving at the speed of light in the opposite direction. The ray conveys no energy. This is a preliminary picture because what we want is a picture of bi-rays $\psi_L \rightleftharpoons \psi_R$. But we have to start somewhere, so we start with two garden variety elementary rays, ψ_L and ψ_R . Each is split into a solid arrow and a dashed arrow in Figure 1 to show the horizontal and vertical projections of such a ray.

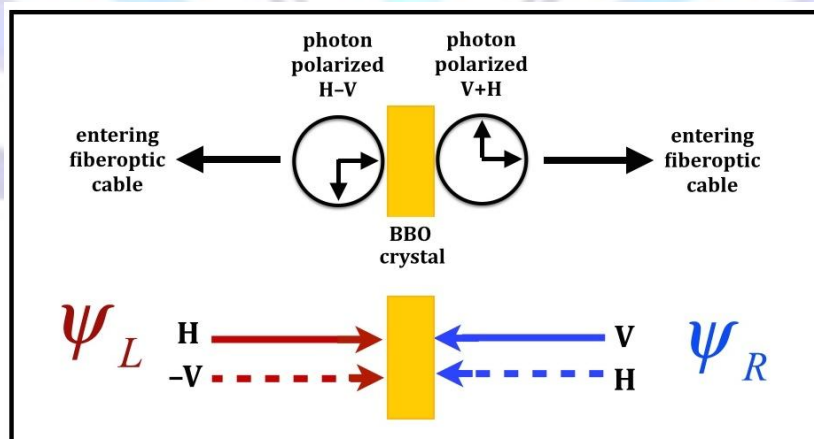

Fig 1: What the BBO crystal does, from QM viewpoint (top ½) versus from TEW viewpoint (bottom ½)

The top half shows two photons emerging from the BBO crystal. Each photon is shown as a white circle that has arrows inside to show their polarization (these are not hands of a clock). These two photons then depart into fiberoptic cables, the left fiberoptic cable going to Alice and the right to Bob. The bottom half of Figure 1 shows a TEW representation of what happened with those photons. To start building a picture of a $\psi_L \rightleftharpoons \psi_R$ bi-ray, we use elementary mono-rays ψ_L and ψ_R from the left and right respectively, impinging on a BBO crystal. The ray from the left, ψ_L is shown as its horizontal and minus vertical projections, corresponding to the H-V polarization of the photon above it. The ray from the right, ψ_R is shown as its vertical and horizontal projections, corresponding to the V+H polarization of the photon directly above it.

We are interested in bi-rays because that is the focus of this article. Introductory TEW is about single rays; advanced TEW about bi-rays. To move from mono- to bi-rays we need to picture both ψ_L and ψ_R penetrating through the BBO crystal and mating with the corresponding elementary ray from the other side. This is shown in Figure 2 (below). But Figure 2 can be confusing because a lot is going on. The rays ψ_L and ψ_R don't just glide straight through the crystal. They twist by $\pm\pi/2$ as they do (this twisting is shown as diagonal lines inside the yellow rectangles of Figure 2). Furthermore the "mating" on the far side of the crystal is complicated. Both vertical and horizontal projections of ψ_L mate with both the horizontal and vertical projections of ψ_R on the right, and vice versa. This twisting and mating produces four eigenstates of the one $\psi_L \rightleftharpoons \psi_R$ bi-ray. These eigenstates are labeled "A, B, C, and D" on the left margin of the diagram. Such eigenstates are orthogonal from a mathematical point of view, but not geometrically perpendicular to each other. Thus we are showing the internal components of a bi-ray, namely four eigenstates, which have rotated by $\pm\pi/2$ passing through the BBO crystal.

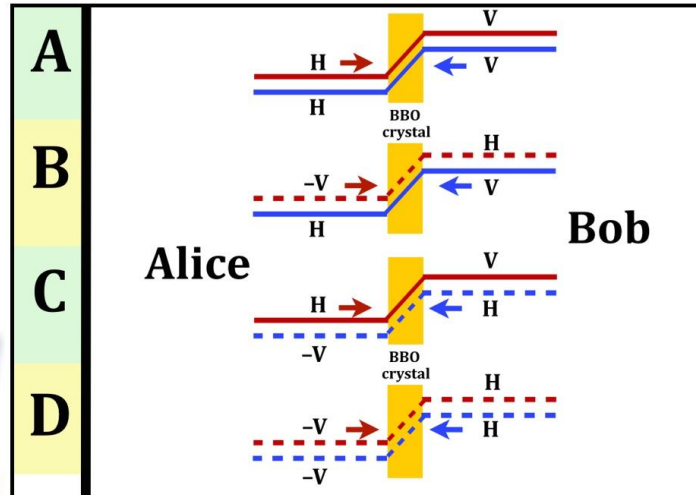

Fig 2: As ψ_L and ψ_R pass through the crystal they rotate & form four eigenstates (A, B, C and D)

This diagram grows out of the bottom diagram in Figure 1, which showed elementary rays ψ_L and ψ_R portrayed as their horizontal and vertical projections, impinging on a BBO crystal. They pass through the crystal to form a $\psi_L \rightleftharpoons \psi_R$ bi-ray. As they move through the crystal they rotate by $\pm\pi/2$ (diagonal lines inside the yellow rectangles). Then each component on the left mates with each component on the right. The top row for example shows the horizontal components of ψ_L and ψ_R joined. Overall there are four rows labeled "A" through "D" on the left margin of Figure 2, representing 4 eigenstates of the $\psi_L \rightleftharpoons \psi_R$ bi-ray.

According to Weihs article, Alice and Bob randomly test the photons by rotating their respective polarizers to angles α and β respectively. As a first approximation we can think of those polarizers sending elementary rays ψ_{ALICE} and ψ_{BOB} centripetally, which are shown as dotted lines in Figure 3. For now we will pretend the polarizers are fixed at angles α and β respectively. We want to know how the ψ_{ALICE} and ψ_{BOB} mono-rays map onto the four eigenstates. We assume that both ψ_{ALICE} and ψ_{BOB} start with a probability amplitude of one, which is a dimensionless number. The amplitude of the mapping is calculated using cosines. For example, focusing on the top left corner of Figure 3, we see a dotted line connecting α with a horizontal red line labeled "H." Alice's ray will map with an amplitude $\cos(\alpha - H)$. This is shown in the top left corner of Figure 4. The mono-rays ψ_{ALICE} and ψ_{BOB} are a temporary device, which later we will discard as unnecessary.

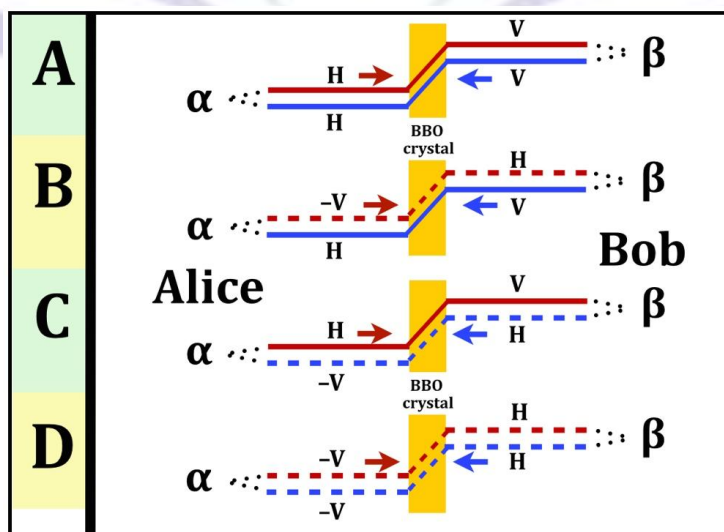

Fig 3: Alice & Bob set their polarizers at angles α and β , which have dotted lines connecting to the bi-ray



The central assumption of introductory TEW is that a photon will strike a detector only if it is following an elementary ray emanating from that detector. We will temporarily think of Alice's detector sending a ray ψ_{ALICE} polarized at angle α in the direction of the BBO crystal. This ray, which has original amplitude of one (dimensionless number) maps onto the four eigenstates A through D at an amplitude calculated by cosines of the angle between ψ_{ALICE} and the angle of the component it is mapping onto. By "amplitude" we mean "probability amplitude." The subsequent cosines in Figure 4 are read directly off this Figure 3 diagram. Warning: the use of mono-rays ψ_{ALICE} and ψ_{BOB} are useful pedagogical devices as we are teaching how a bi-ray model works, but later we will discard these mono-rays (ψ_{ALICE} and ψ_{BOB}) and explain the experiment by using the $\psi_L \rightleftharpoons \psi_R$ bi-ray alone.

One law of probability is $P(A \text{ and } B) = P(A) \cdot P(B)$. Let's focus on the top line of cosines in Figure 4 (below). Alice's elementary ray ψ_{ALICE} , polarized at angle α , maps onto both components of the bi-ray, so we have to multiply $\cos(\alpha - H)$ x $\cos(\alpha - H)$ where red means it is moving from left to right as a component of ψ_L and blue means it is a component of ψ_R . This explains the upper left corner of the "A" eigenstate of a red and a blue cosine, shown in Figure 4.

If we think about the research question for this experiment, it has to do with two photons being simultaneously seen hundreds of meters apart. As Alice's photon is following ψ_{ALICE} its twin is following ψ_{BOB} . Our research question concerns both events happening simultaneously. Based on the same law [$P(A \text{ and } B) = P(A) \cdot P(B)$] we need to multiply the two cosines from the last paragraph with the corresponding two cosines from Bob's side. This gives us the top line of Figure 4: $[\cos(\alpha - H) \times \cos(\alpha - H)] \times [\cos(\beta - V) \times \cos(\beta - V)]$. This sequence of four cosines tells us the probability in the first eigenstate of Alice and Bob simultaneously seeing a photon with their polarizers rotated to random angles α and β respectively.

There are four eigenstates, "A, B, C and D" shown on the left margin of these diagrams. By the nature of eigenstates, something can happen via "A" or "B" or "C" or "D". Another law of probability is $P(A \text{ or } B) = P(A) + P(B)$. In Figure 4 there are four lines of trigonometry code that are added together vertically [$P(A) + P(B) + P(C) + P(D)$], to arrive at the overall probability of Alice and Bob simultaneously seeing a photon with their polarizers rotated to random angles α and β . This monstrous equation can easily be simplified.

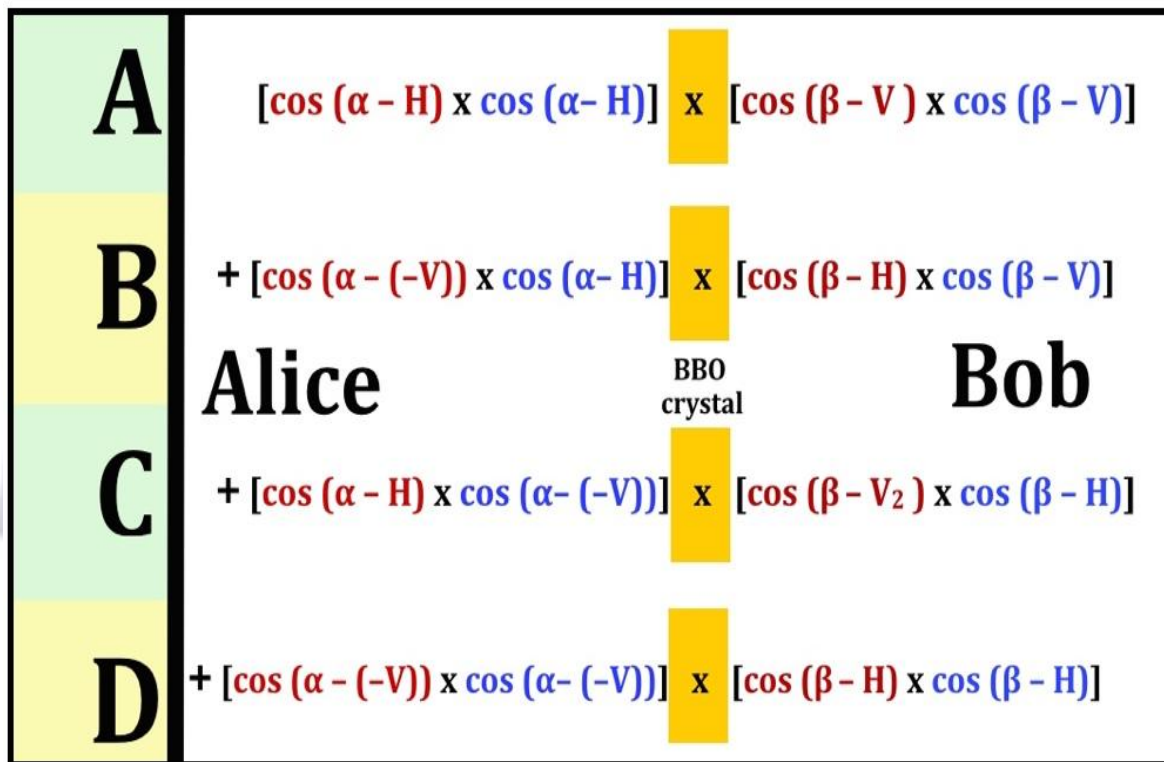

Fig 4: The cosines for each of the four eigenstates (A through D) consist of four cosines each

As noted in the caption to Figure 3, the cosines here are read directly off Figure 3, and depend on the angle between Alice's angle α of the mono-ray ψ_{ALICE} (or Bob's angle β of the mono-ray ψ_{BOB}) and the horizontal or vertical component of the bi-ray eigenstates. In the upper left, Alice's ψ_{ALICE} at angle α maps onto both prongs of the bi-ray (red and blue). Since these are both part of the same eigenstate A, so we multiply the cosines. Since our research question concerns the simultaneous visibility of a photon to Alice and Bob, we need to move across the yellow rectangle (representing the BBO crystal) to Bob's side of the equipment. Within eigenstate A we need to multiply Alice's two cosines by the corresponding two cosines for Bob's β . That explains the top row of Figure 4, consisting of four cosines multiplied together. The four eigenstates are orthogonal to one another, so we use the law of probability which says $P(A \text{ or } B) = P(A) + P(B)$, and add the four lines of code vertically.

$$\begin{aligned}
 &= [\cos \alpha \times \cos \alpha] \times [\sin \beta \times \sin \beta] \\
 &- [\sin \alpha \times \cos \alpha] \times [\cos \beta \times \sin \beta] \\
 &- [\cos \alpha \times \sin \alpha] \times [\sin \beta \times \cos \beta] \\
 &+ [\sin \alpha \times \sin \alpha] \times [\cos \beta \times \cos \beta]
 \end{aligned}$$

BBO crystal

which can be factored

$$\begin{aligned}
 &= [\cos(\alpha) \sin(\beta) - \sin(\alpha) \cos(\beta)] \times \\
 &[\cos(\alpha) \sin(\beta) - \sin(\alpha) \cos(\beta)]
 \end{aligned}$$

which equals

$$\begin{aligned}
 &= \sin(\beta - \alpha) \times \\
 &\sin(\beta - \alpha) \\
 &= \sin^2(\beta - \alpha)
 \end{aligned}$$

Fig 5: Grinding through the trigonometry from Figure 4, we end up with $\sin^2(\beta - \alpha)$ at the bottom

The trigonometry in Figure 4 can be simplified, as shown here. Throughout all these Figures red means it is related to ψ_L and blue means it is related to ψ_R . The final product, at the bottom, shows the probability of Alice and Bob simultaneously seeing a photon, when they randomly set their polarizers at any arbitrary angles α and β , whether or not there is delayed choice.

Figure 5 grinds through the machinery of trigonometry to arrive at the net result at the bottom of Figure 5, which is that the probability in question is $\sin^2(\beta - \alpha)$. QED

We have been talking as if Alice and Bob kept their polarizer angles constant. But in reality in Innsbruck the angle of the polarizers was changing every 10 ns, while the photons each were traveling 500 m from the BBO crystal through their respective fiberoptic cables. In an earlier publication about the Aspect experiment we showed that delayed choice makes no difference to our calculations. It is a tedious argument that we will not repeat here.

Now lets picture the internal structure of the bi-ray in the Weihs experiment. Figure 6 shows a piece of graph paper upon which Alice and Bob might chart their polarizer angles, from zero to 2π . The probability of them simultaneously seeing a photon will be charted on the vertical axis, as shown in Figure 7. This graph looks like ocean waves but they are stationary waves and have nothing to do with water.

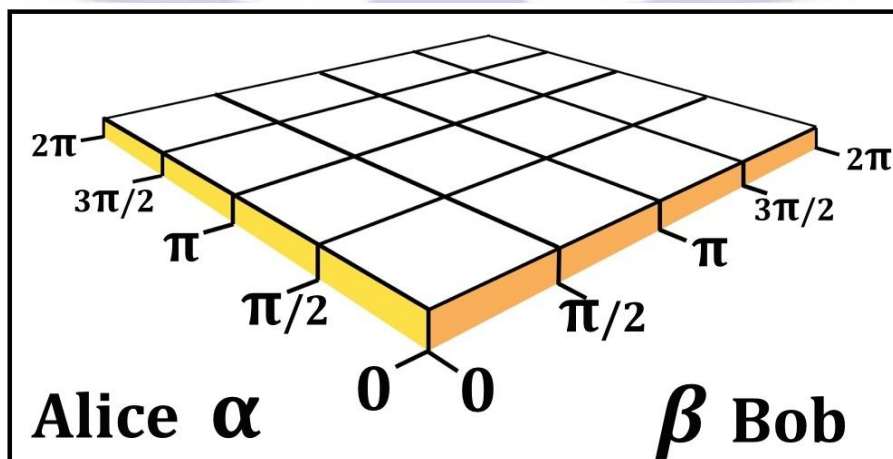

Fig 6: To understand the internal structure of the $\psi_L \rightleftharpoons \psi_R$ bi-ray we will use this graph paper

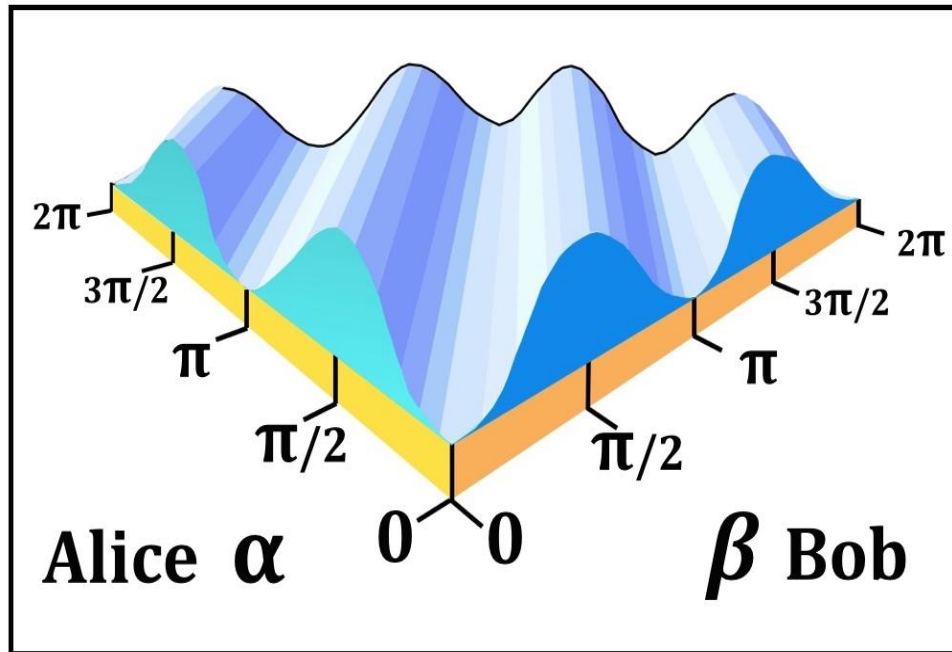

Fig 7: The z axis represents $\sin^2(\beta - \alpha)$ mapped on the graph paper shown in Figure 6

Although these blue waves appear to be ocean waves, they are neither water nor moving over time. The vertical axis represents the probability of Alice and Bob simultaneously seeing a photon, given that they set their polarizers at arbitrary angles α and β . This is a picture of what happens inside the $\psi_L \rightleftharpoons \psi_R$ bi-ray.

4. Broader issues

Many people are interested in whether the Bell test model can be used for long distance communication faster than the speed of light. Figure 7 shows us the contingency probabilities upon which such communication would need to be built. Suppose Alice has set her polarizer to angle θ , and Bob is a zillion kilometers away. What is the probability that Bob will set his polarizer to angle ξ ? The answer is $\sin^2(\xi - \theta)$. It is difficult to see how that information would be much use as a basis for communication, because Alice already knew that.

Earlier we used a temporary device, mono-rays ψ_{ALICE} and ψ_{BOB} , which allegedly emanated from Alice and Bob's polarizers. That was a useful pedagogical device. But it isn't logical to have mono-rays running around the corners of our bi-ray model. We need to extend the concept of bi-rays into every nook and cranny of the experiment. So we now discard ψ_{ALICE} and ψ_{BOB} .

Here's the correct picture. There is an invisible bi-ray contraption lurking inside the equipment of the Innsbruck physics department. It lives there 24-7, meaning 24 hours a day, seven days a week, even when the electricity is turned off and the physicists are elsewhere having a party on Saturday night. The bi-ray thrives on zero energy. Monday morning when the physicists turn on the electricity, their Argon-ion-laser begins feeding photons into the BBO crystal. The photons make the invisible bi-ray visible. The bi-rays impinge on Alice and Bob's equipment. Alice decides to ask her bi-ray a question. She asks, "If I set my polarizer to angle α , how often will I see a photon?" Every polarization is already embedded in the bi-ray, so the bi-ray is perfectly capable of answering Alice's question.

Meanwhile 400 k away Bob is asking his end of the bi-ray, "If I set my polarizer to angle β , how often will I see a photon?" Three computers are used. One collects the answers to Alice's question, along with time tags produced by an atomic clock. The second collects the corresponding answers to Bob's question. The third computer is used at a later time, to correlate the two datasets by aligning the time tags, to produce what is called "coincidence rates," meaning the coincidence of both photons being simultaneously seen in accordance with the sinusoidal curve $\sin^2(\beta - \alpha)$. As you can see, this picture of reality is based entirely on bi-rays, with no use of mono-rays.

Clarifying one of the peculiarities of the ideas presented above, we need to explain why the bi-rays rotated by $\pm\pi/2$ passing through the BBO crystal in Figure 2. This is the elementary ray translation of the Weihs report that the BBO crystal produced photons polarized at H-V versus V+H. Therefore our impinging rays were polarized at H-V on the left, and V+H on the right. This $\pm\pi/2$ twist is what happened inside the BBO crystal when the two photons were born. Had there been no twist, the photons would not have been polarized orthogonally. For example, we showed in another article that if a calcium cascade source produced photons polarized at HH-VV then the resulting probability would be $\cos^2(\beta - \alpha)$. So if you change the source so as to change the relative polarization of the two photons, you thereby change the trigonometry produced by the presence or absence of a twist internal to the 2-photon source.



5. Cautions

It is probable that there are mistakes in this article. Whereas QM has had a century of the greatest geniuses of all time contributing to it, the same is not true of TEW, a theory that is almost unknown to mainstream physics.

It may well be that the bi-ray mechanism is the wrong model for how to solve the Bell test enigma. It is possible that there are a dozen or more implications or glitches that make this model untenable from some perspective we never even thought about, such as the implication for a Higgs boson, quark or the Dirac equation. The more this author thinks about polarization, the more unsure he is of what polarization means. TEW is a turbulent, creative and sometimes combative construction site. Ideas that emerge in the future may not resemble the ideas here proposed. Even a stupid idea is often useful because it provokes others to formulate a better idea.

6. Conclusion

We cautiously present this interpretation of the Weihs experiment, for the purpose of showing that there could be a local realistic interpretation of the data which neither the experimenters, nor CHSH, nor Bell, nor Einstein, nor Popper ever considered. This article is designed to support the previous article in this journal in which we sketched the nature of TEW, but failed to demonstrate how TEW could interpret a Bell test experiment in a local and realistic manner.

We have the utmost admiration for Weihs and colleagues, and for the physicists who contributed such riches to quantum mechanics. Quantum mathematics is the most accurate and productive science of all time. We stand on the shoulders of giants. As noted in the previous article, our view is that TEW can provide a better foundation for quantum mathematics than can wave particle duality. They are mutually incompatible.

It would be a mistake for the reader to think that this article is motivated by a desire for recognition. The greater likelihood is that we have provoked a firestorm of hostility. So the question arises, what motivates this article? The answer is simple. This author has identified with the scientific community his entire life, from as far back as he can remember. The author's responsibility is to bring to community attention any idea that might launch a breakthrough in science, even if that idea proves to be wrong. He is an old man who lives outside of the world of academic physics. This author is more afraid of ending his days without having discharged his duty, than he is of the upcoming firestorm.

ACKNOWLEDGMENTS

Some ideas in this article are based on my interpretation of Lewis E. Little's TEW theory as of 2012 conversations he and I had. We are cousins and were talking for more than fifty years. If I am like the moon shedding light on TEW, Dr. Little is like the sun.

REFERENCES

- [1] J. H. Boyd, The Theory of Elementary Waves eliminates Wave Particle Duality, *Journal of Advances in Physics*, (in press February 2015).
- [2] A. Einstein, B. Podolsky, and N. Rosen, "Can quantum-mechanical description of physical reality be considered complete?" *Physical Review*, **47**, 777 – 780 (1935).
- [3] A. Aspect, J. Dalibard, G. Roger, Experimental test of Bell's inequalities using time-varying analyzers, *Physical Review Letters* **49**, 1804-1807 (1982).
- [3] J.H. Boyd, Re-thinking Alain Aspect's 1982 Bell test experiment with delayed choice, *Physics Essays* **26**, 582–591 (2013).
- [4] G. Weihs, T. Jennewein, C. Simon, H. Weinfurter, and A. Zeilinger, Violation of Bell's inequality under strict Einstein locality conditions, *Physical Review Letters* **81**, 5039 (1998), DOI: 10.1103/PhysRevLett.81.5039.
- [5] N. D. Mermin, "Is the moon there when nobody looks? Reality and the quantum theory," *Physics Today*, **38**, 38-47 (April 1985).
- [6] Bell, J. S., On the Einstein Podolsky Rosen paradox, *Physics* **1**, 195-200 (1964).
- [7] Bell, J.S., The paradox of Einstein, Podolsky and Rosen: action at a distance in quantum mechanics?, *Speculations in Science and Technology*, **10**, 269–285 (1987).
- [8] Clauser, J.F., Horne, M.A., Shimony, A. and Holt, R. A., "Proposed experiment to test local hidden-variable theories," *Physical Review Letters*, **23**, 880 - 884 (1969).

Author's biography with Photo



Dr. Boyd was born in 1943 in New Jersey, USA. Boyd's undergraduate degree in mathematics was from Brown University. He has advanced degrees from Harvard, Yale and Case Western Reserve Universities, served on the faculty of the National Institutes of Health for 7 years, and has been on the faculty of the Yale Medical School. His day job is as a physician, which is fortunate because he need not fear he is risking a career in physics by speaking in public about these controversial ideas. Boyd retired after a quarter century at Waterbury Hospital, Waterbury CT, a Yale teaching hospital. He has published in the New England Journal of Medicine, Journal of Advances in Physics and Physics Essays.