



## A DESIGNED METHOD FOR 48-PULSE DIODE RECTIFIER WITH COUPLED THREE PHASE REACTOR

S.Kirthika, P.Alageswari, R.Senthil Kumar  
Assistant Professor, M.Kumarasamy College of Engineering, Karur.  
kirthikaselvam26@gmail.com  
Assistant Professor, M.Kumarasamy College of Engineering, Karur.  
alageswariabi@gmail.com  
Assistant Professor, M.Kumarasamy College of Engineering, Karur.  
senthilme90@gmail.com

### ABSTRACT

This paper presents a designed methodology for power electronics, which converts AC into DC voltage with a system of three-phase coupled reactors which secures consumption of the current. In order to reduce to ripples, here pure inductor is used from the supply itself. Here eight diode bridge rectifier is also used to get 48 pulses then it will apply to the DC load. This work consists of simulation result, designed topology of a 2-kVA model of 48-pulse converter system. While converting 24 pulse converter to 48 pulse converter the power quality problems like harmonics and Total Harmonic distortion is greatly reduced. The main advantage of this converters is to reduce the consumption of the deformation power. Here 48 pulse diode rectifier with couples three phase reactor is simulated using MATLAB/SIMULINK software.

### Keywords

Multi pulse converters, Phase shifting transformer, coupled three phase reactors, Bridge Rectifiers, Total Harmonic Distortion (THD).

### I. INTRODUCTION

Many converters realize the concept of fully controlled semiconductor devices, like Gate Turn-off thyristors, power transistors using pulse width modulation techniques. The conversion of alternate current to direct current is the concept of power electronic converters [1],[2]. The two coupled reactors has to be connected between the supply line and the semiconductor rectifier.

Without using the transformer we can able to convert the 3-phase voltage into number of phases by using coupled reactors. And also the power of couples reactors is comparatively low compared to other converters [3]. Obtaining reduction in deformation power is achieved by increasing number of phases of input voltage. The converter transformers are replaced by coupled reactors, so that the power is greatly reduced. The application of three phase coupled eight phase shifted system, which will allow the eight six-pulse rectifier at its input parameter. The rectifier convert alternating current into direct current flows only in one direction. The main applications of rectifiers is to give supply for radio, television which requires constant DC current.

### II. DIODE BRIDGE RECTIFIER-24 PULSE

The rectifier which will converts the alternating current into direct current. This process is called as rectification. The simulation diagram represent the non adjustable rectifier with 12 pulse which is supplied by a phase voltage of  $u_p$  ( $p=R,S,T$ ). The circuit is connected in series with the coupled three phase reactor CTR2 power network and linear reactors L. The two coupled reactors CTR1 and CTR2 are connected in parallel. The input of the reactor CTR2 is given by the supply network through linear reactors L. The output of the reactor is used as the supply for the reactors CTR1 and CTR3. The output of CTR1 and CTR3 are linked with 3 phase bridge rectifier. The terminals of DC are connected in parallel to the capacitor which is used for filtering [4],[5].

The coupled reactors produces three alternating voltages  $u_{Gp}$  in the form of sine. Using the four bridges valves, the DC voltage  $2E_d$  can be measured by the initial star point zero of its supply circuit. [6]. The diode will conduct only when the voltage period is half of the supply line to meet 24 pulse waveform.

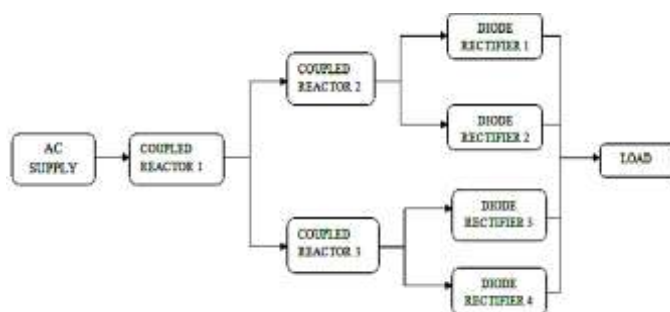

Fig.1. Block Diagram Of 24 Pulse Diode Rectifier

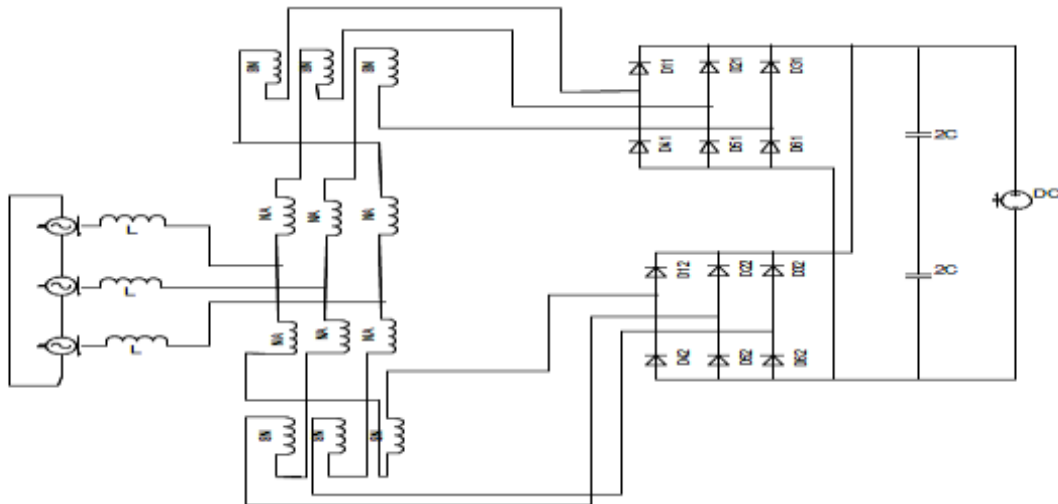

Fig 2. Simulation diagram for 24 pulse diode rectifier

### III. DIODE BRIDGE RECTIFIER-48 PULSE

The pulse width modulation topology is determined by using 48 pulse converter will remove the harmonics produced by the non linear load system. The different methods are used to remove the harmonics. This work explains the voltage source converter for 48 pulse with pulse width modulation topology. [7],[8]. To firing the gate pulse of switching devices the pulse width modulation technologies like delta modulation, sinusoidal pulse width modulation, multiple pulse width modulation, single pulse width modulation, space vector pulse width modulation used. To obtain the greater pulse rather than the conventional pulse width modulation technology inverted sine pulse width modulation are used. So that it will reduces the harmonics losses and switching losses.

### IV. VOLTAGE SOURCE CONVERTER

The performance of different transmission application can be installed by using HVDC and FACTS devices. To obtain the asynchronous inter connection, long distance bulk power transmissions and large cable sub-marines the high voltage direct current is used. The analyses of dynamic reactive power is provided by static VAR compensator which will give rise to limiting the power transfer. The large power can be transmitted over a small transmission line by using HVDC and FACTS devices.

The replacement of deregulated power generation, differences in production cost and trouble in implementing transmission lines leads to pay attention to HVDC and FACTS transmission. To meet the transmission dare, flexibility can be increased by implementing new technologies like HVDC and FACTS. The voltage source converter topologies ids determined by the HVDC transmission system and reactive power compensation to obtain the overall performance of the system. The employs of ABB develops two technologies namely HVDC Light™ and SVC Light™ where voltage source converters are connected in series with valves of of insulated gate bipolar transistor which can be controlled with pulse width modulation.

Voltage Source Converters operating with the specified vector control strategy can perform independent control of active and reactive power at both ends. To manage the real and reactive power for power transmission the voltage source converter is used. The interconnection of alternating current system is determined by using dynamic voltage regulation. This will increase the whole transfer level. The voltage source inverter will accept the black start in forced commutation i.e a synchronous machine can produce a balanced three phase voltage by using the converter. The basic configuration of HVDC are used in voltage source converter which represents a two level VSC converter.

The two level voltage source converter also named as six pulse bridge converter, three phase two level converter which is easily configure for HVDC transmission system. This converter includes six valves. In that each valve is having anti-parallel diode and IGBT switches and it obtain the two voltage level of  $-0.5V_{dc}$  and  $+0.5V_{dc}$ . This topology consists of four valves in each one arm of the converter.

### V. VSC WITH 48 PULSE

The three level 48 pulse voltage source converter produces low harmonic distortion. So it can able to decreases the power quality problems when compare to other converter like 6, 12, 24 pulse. This will be able to reduce the harmonic



instability fault and overload operation to get a better voltage stability performance condition [9],[10]. The 48 pulse fully controlled converter operation is obtained by using two 24 pulse GTO converter with the phase shift of 7.5°

The two coupling transformer of 24 pulse converter produces phase shift of -3.75° and the other 24 pulse converter produces +3.75°. The triggering pulse requires only +3.75°. The 48 pulse VSC has 12 –pulse GTO converters by connecting four 12 pulse bridge rectifier [11],[12]. The main advantage of 48 pulse is to be used in high voltage high power applications by filtering AC filters because of its low harmonic distortion level on the alternating current side. The ordinary harmonics of the output voltage is  $n=48r+1$  where  $r=0,1,2,3, \dots$ . Which implies 47, 49, 95, 98<sup>th</sup> harmonic with the magnitude of  $1/47^{th}$ ,  $1/49^{th}$ ,  $1/95^{th}$ ,  $1/97^{th}$  ...respectively on the direct current side.

The output voltage of 1<sup>st</sup> 12 pulse converter is

$$V_{ab12}(t)_1 = 2[V_{ab1}\sin(\omega t + 30^\circ) + V_{ab11}\sin(11\omega t + 195^\circ) + V_{ab13}\sin(13\omega t + 255^\circ) + V_{ab23}\sin(23\omega t + 60^\circ) + V_{ab25}\sin(25\omega t + 120^\circ) + \dots] \quad (1)$$

The output voltage of 2<sup>nd</sup> 12 pulse converter is

$$V_{ab12}(t)_2 = 2[V_{ab1}\sin(\omega t + 30^\circ) + V_{ab11}\sin(11\omega t + 15^\circ) + V_{ab13}\sin(13\omega t + 75^\circ) + V_{ab23}\sin(23\omega t + 60^\circ) + V_{ab25}\sin(25\omega t + 120^\circ) + \dots] \quad (2)$$

The output voltage of 3<sup>rd</sup> 12 pulse converter is

$$V_{ab12}(t)_3 = 2[V_{ab1}\sin(\omega t + 30^\circ) + V_{ab11}\sin(11\omega t + 285^\circ) + V_{ab13}\sin(13\omega t + 345^\circ) + V_{ab23}\sin(23\omega t + 240^\circ) + V_{ab25}\sin(25\omega t + 300^\circ) + \dots] \quad (3)$$

The output voltage of 4<sup>th</sup> 12 pulse converter is

$$V_{ab12}(t)_4 = 2[V_{ab1}\sin(\omega t + 30^\circ) + V_{ab11}\sin(11\omega t + 105^\circ) + V_{ab13}\sin(13\omega t + 165^\circ) + V_{ab23}\sin(23\omega t + 240^\circ) + V_{ab25}\sin(25\omega t + 300^\circ) + \dots] \quad (4)$$

These four 12 pulse converter gives shifted AC output voltages which are connected in series with secondary winding of phase shifting transformers.

$$V_{ab48}(t) = V_{ab12}(t)_1 + V_{ab12}(t)_2 + V_{ab12}(t)_3 + V_{ab12}(t)_4 \quad (5)$$

$$V_{ab48}(t) = 8[V_{ab1}\sin(\omega t + 30^\circ) + V_{ab47}\sin(47\omega t + 150^\circ) + V_{ab49}\sin(49\omega t + 210^\circ) + V_{ab95}\sin(95\omega t + 330^\circ) + V_{ab97}\sin(97\omega t + 30^\circ) + \dots] \quad (6)$$

The 48 pulse output voltage is given by

$$V_{an48}(t) = \frac{8}{\sqrt{3}} \sum_{n=1}^{\infty} V_{ab} \sin(n\omega t + 18.75^\circ n - 18.75^\circ) \quad (7)$$

Similarly the voltages  $V_{bn48}(t)$  and  $V_{cn48}(t)$  have sinusoidal waveforms by having a phase shifting with 120° and 240°. Comparing The 48 pulse VSC with other pulse power quality problems are highly reduced. This also further gives results in operational overloading, instability harmonic problems and accurate better prediction of current and voltage[13]. By using symmetrical phase shifting, two 24 pulse converters are shifted by 7.5°. The 1<sup>st</sup> 24 pulse converter which is connected with two coupling transformer produces shifting by 3.75°. The remaining transformer gives -3.75° of phase shifting. The circulating DC current content will be lower in 48<sup>th</sup> pulse[14].

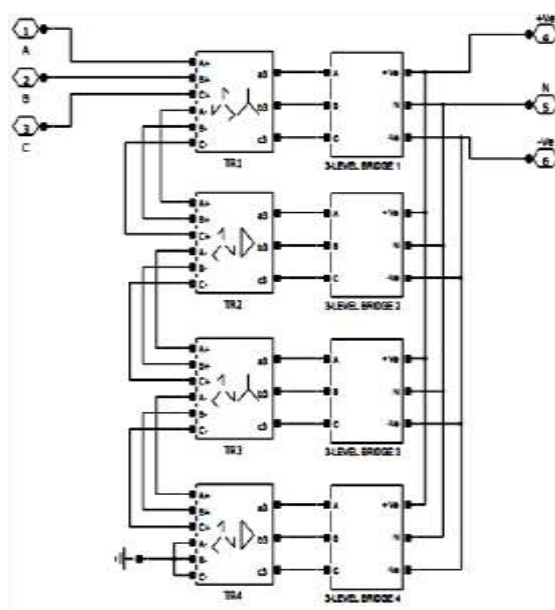

Fig 3.48 pulse VSC Converter

## V. SIMULATION RESULTS

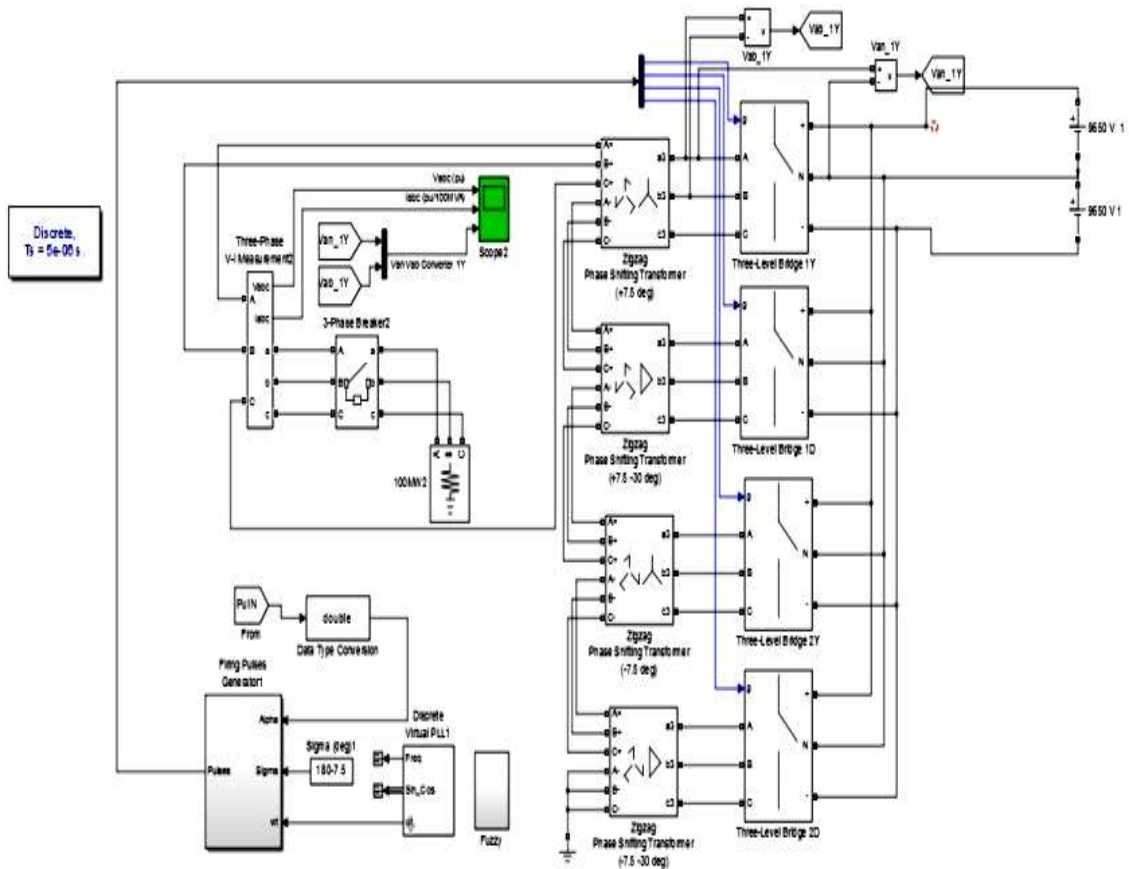

Fig. 4 Simulation block for 48 Pulse Diode Rectifier

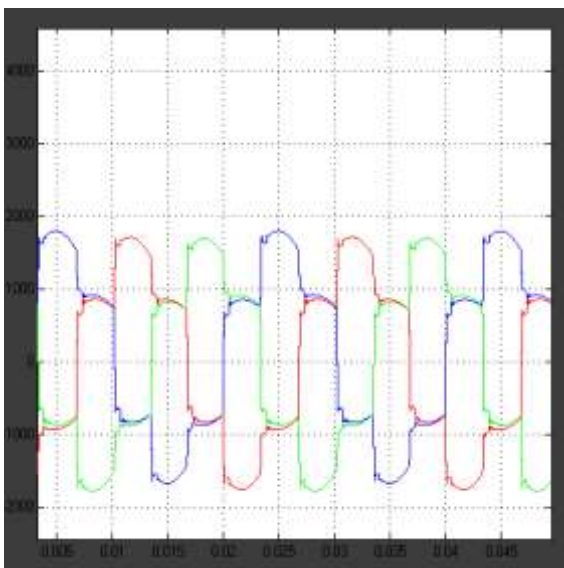

Fig.5 Input voltage waveform

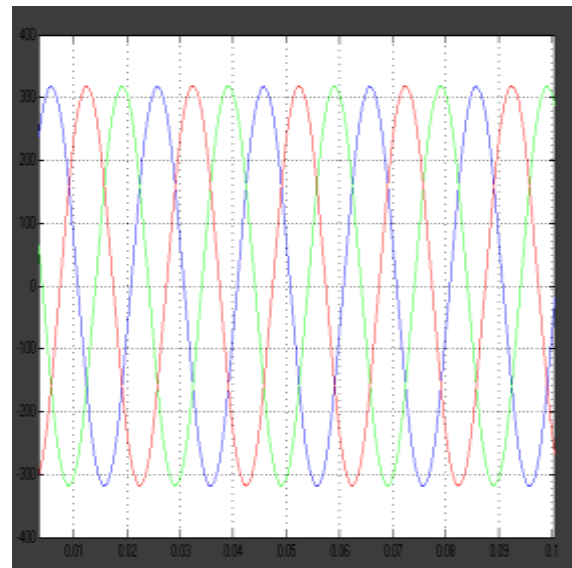

Fig.6 Input current waveform

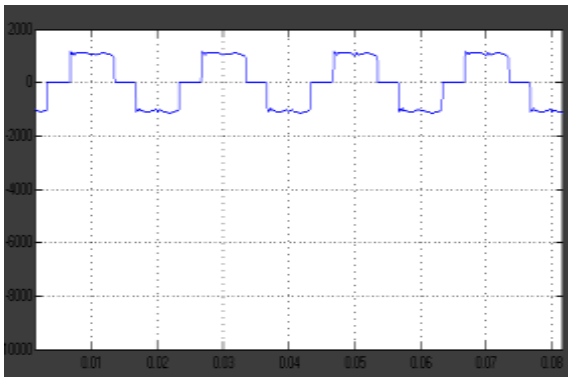

Fig.7 Input rectifier voltage waveform

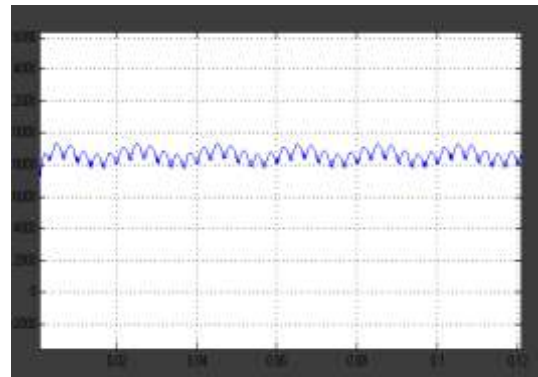

Fig.8 Output rectifier voltage waveform

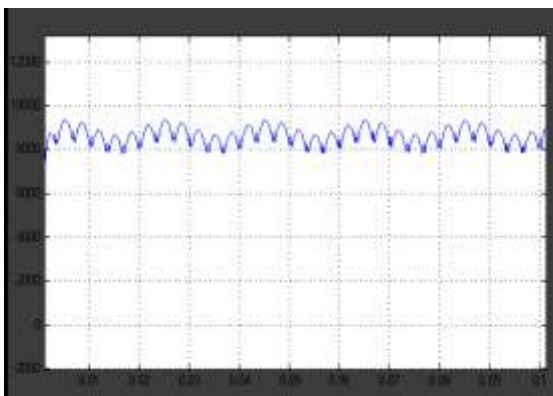

Fig.9 Output load Voltage waveform

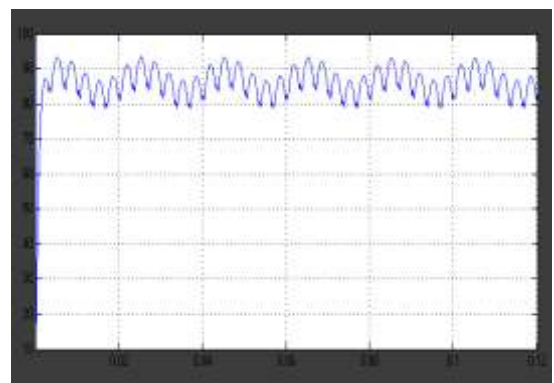

Fig.10 Output load current waveform

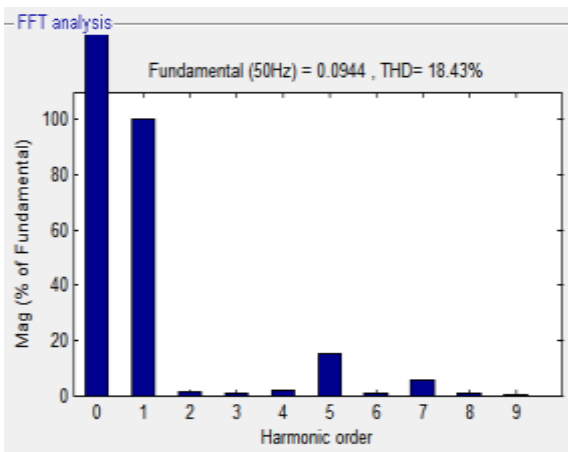

Fig.11 FFT Analysis waveform

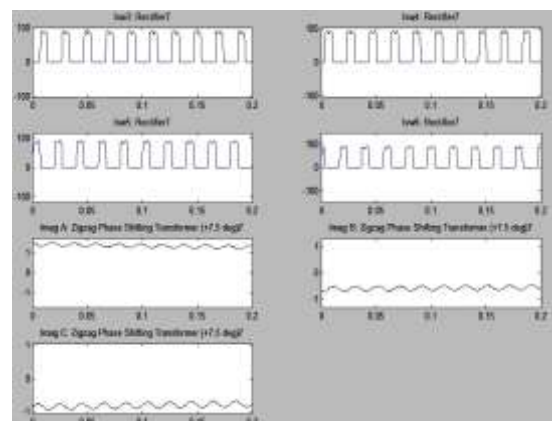

Fig.12 Phase shifting waveform

Fig.11. Shows the FFT analysis waveform. The FFT is the Fast Fourier Transform algorithm that computes the discrete fourier transform in the sequence of its inverse. A fourier analysis converts the signal from its original domain to the frequency domain. The application of fast fourier transform is fast large integer, filtering algorithm, fast differential equation.



S.No	Components	Coupling Transformer	Power Transformer
1	Rated voltage	25/500KV	500/33 KV
2	Rated Power	100 MVA	300 M
3	Resistance	0.001 pu	0.002 pu
4	Leakage reactance	0.08 pu	0.01 pu

Table. 1 Components requirement

## VI.CONCLUSION

This paper presents modeling and simulation of a two level 48 pulse VSC for HVDC system. A set of two 24 pulse converter forms 48 pulse converter which is operated at fundamental frequency switching (FFS). By reducing harmonics and Total Harmonic Distortion (THD) the performance of the system is improved. The performance of compensated reactive power, improvement in power factor and reduction in harmonics are studied in terms of VSC. The control algorithm at fundamental frequency switching of the converter is discussed in detail. Simulation results shows the response of multi pulse diode rectifier for variable loads. Here 48 pulse diode rectifier with couples three phase reactor is simulated using MATLAB/SIMULINK software.

## REFERENCES

1. Mysiak .P New method for reducing harmonics involved in input and output of rectifier with interphase transformer. IEEE Trans. on Ind. Aplic. 1986.
2. Mysiak P An DC-output multi pulse converter in the low voltage power network supply conditions. Doctor's thesis, War-saw University of Technology, Warsaw 1996.
3. K Sundararaju, AN Kumar , "Cascaded and Feed forwarded Control of Multilevel Converter Based STATCOM for Power System Compensation" International Review on Modelling and Simulations (I. RE. MO. S.) vol. 5 (2), pp. 609-615.
4. S.K.Nandhakumar and P.Alageswari, 'Performance analysis of MPPT algorithms for PV array fed SEPIC converter' Pakistan Journal of Biotechnology., Vol. 13, pp. 342-346, 2016
5. R.senthil kumar, s.mahesh,"Fault detection and diagnosis of induction motor using IFOC",International journal of applied engineering research,Volume 11,No.3,Pages 781-788,,ISSN 0973-4562
6. S.murugesan,R.Senthil kumar,"Design of single phase seven level inverter PV inverter using FPGA",International journal of emerging technology in computer science & Electronics,Volume 20,Issue 2,Feb 2016,Issn :0976-1353
7. Draft-Revision of Publication IEC 555-2: Harmonics, Equipment for Connection to the Public Low Voltage Supply System, IEC SC 77A, 1990.
8. An efficient multilevel inverter system for reducing THD with Space Vector Modulation R Karthikeyan, SC Pandian International Journal of Computer Applications 23 (vol. 2), 0975-8887
9. Bhim Singh, B. N. Singh, A. Chandra, Kamal Al-Haddad, Ashish Pandey, and D. P. Kothari, "A Review of Three-Phase Improved Power Quality AC-DC Converters", IEEE Trans. Ind. Electron., vol. 51, No. 3, pp. 641–660, June 2004.
10. S. Choi, "New pulse multiplication technique based on six-pulse thyristor converters for high power applications," IEEE Trans. Ind. Appl., vol. 38, no. 1, pp 131–136, Jan./Feb. 2002.
11. K.Sundararaju,,R.Senthil Kumar,"Modeling and analysis of real time PS with cascaded multilevel STATCOM using Fuzzy controller", International journal of Advance in Chemistry,vol.12,issue10,Oct 2016
12. P.Alageswari and S.K.Nandhakumar, 'Design of SM controller technique for photo voltaic system with DC-DC converter,' International journal of system design and information processing., Vol. 3, No. 1, pp. 1-5, August 2016
13. M. Villablanca, J. D. Valle, J. Rojas, and W. Rojas, "A modified backto- back HVDC system for 36-pulse operation," IEEE Trans. Power Del., vol. 15, no. 2, 641–645, Apr. 2000.



S.Kirthika received UG degree from karpagam college of Engineering, Coimbatore, Tamilnadu on 2013. She got PG degree from SBM college of Engineering and Technology, Dindigul, Tamilnadu on 2015. she attended more conferences and presented more reputed papers in the field of Power Electronics and Drives. Currently She is working as an Assistant Professor in M.Kumarasamy College of Engineering, Karur. Her interest is in the field of Power electronics, control systems and soft computing techniques.



P. Alageswari received UG degree from PSNA college of Engineering, Dindigul, Tamilnadu on 2014. She got PG degree from the same college on 2016. She attended more conferences and presented more reputed papers in the field of Power Electronics and Drives. Currently she is working as an Assistant Professor in M.Kumarasamy College of Engineering, Karur. Her interest is in the field of Power electronics, solar systems and soft computing techniques.



R. Senthil Kumar received UG degree from PSNA college of Engineering, Dindigul, Tamilnadu on 2011. He got PG degree from the same college on 2013. He attended more conferences and presented more reputed papers in the field of Power Electronics and Drives, Renewable energy sources. Currently he is working as an Assistant Professor in M.Kumarasamy College of Engineering, Karur. His interest is in the field of Power electronics, control systems, soft computing techniques and AC drives.