



Chemical and Electrochemical studies on the corrosion of mild-steel, copper and zinc in 0.5 M H₂SO₄ solution in presence of Azithromycin as effective corrosion inhibitor

O. A. Abdullatef

Pharos University, Faculty of Pharmacy (Corresponding author) KanalElmahmodiastreet, Smoha, Alexandria, Egypt

Tel: 002033877032/033; 0201226594955 Fax: 002033877149

E-mail address: ossama_abdullatef@yahoo.com

ABSTRACT

Azithromycin has been tested as inhibitor for steel, copper and zinc corrosion in 0.5 M H₂SO₄ using potentiodynamic polarization and electrochemical impedance spectroscopy (EIS) techniques. The results showed that the inhibition efficiency increased with increasing the concentration of Azithromycin. The adsorption characteristics of Azithromycin in presence of steel, copper and zinc metals were studied and the data found to fit the Kinetic-Thermodynamic model. IR spectroscopy of the corrosion product with the inhibitor confirmed the formation of metal ion inhibitor complex, UV-Visible spectrophotometry showed the formation of 1:1 metal ion-inhibitor complex.

Key words: *acidic; corrosion; electrochemistry; inhibitor; steel; copper; zinc.*



Council for Innovative Research

Peer Review Research Publishing System

Journal: Journal of Advances in Chemistry

Vol. 11, No. 6

editorjaonline@gmail.com, www.cirjac.com



1. INTRODUCTION

Chemical inhibitors are important and have great uses in the protection and retardation of corrosion [1, 2]. Compounds containing heteroatoms (O, N, S and P) and having unsaturated bonds are the most effective inhibitors [3-8]. Nowadays, drugs can replace traditional toxic corrosion inhibitors due to their non-toxic characteristics [9] and their positive impact on the aquatic environment [10]. Flouroquinolones have been evaluated as corrosion inhibitors for mild steel in 3.4 % sodium chloride containing different concentrations of flouroquinolones, by mass loss and electrochemical polarization techniques. The efficiency of flouroquinolones as inhibitors increased with increasing the concentration of inhibitors and was arranged in the order: Ofloxacin > amifloxacin>enofloxacin>pifloxacin> ciprofloxacin >norofloxacin. A thin layer of inhibitors is adsorbed on the metal surface and acts as a protective barrier against corrosion [11]. Flouroquinolones was studied as corrosion inhibitor for mild steel in H₂SO₄ by mass loss, the results indicated that ciprofloxacin, norofloxacin, ofloxacin and sparofloxacin are effective corrosion inhibitors and their adsorption on mild steel surface is consistent with Langmuir adsorption isotherm [12]. Cefotaxim sodium has been studied as a new efficient corrosion inhibitor for mild steel in hydrochloric acid solution by weight loss, electrochemical polarization, and impedance measurements. The results explained the inhibition process in terms of adsorption of the inhibitor on the metal surface without changing the mechanism of corrosion process [13]. The efficiency of inhibition and inhibition mechanism of pipemidic acid, levofloxacin and ciprofloxacin for mild steel in 0.5 M H₂SO₄ was studied by mass loss, potentiodynamic polarization, electrochemical impedance (EIS) and scanning electron microscope (SEM) techniques. The results showed that the inhibition efficiency increased with increasing inhibitor concentration and the results is consistent with Langmuir isotherm model [14]. The present study aims to evaluate the potential of Azithromycin as a corrosion inhibitor for steel, copper and zinc in 0.5 M H₂SO₄ solution by using potentiodynamic polarization, electrochemical impedance (EIS) methods and study the reaction between the metal and inhibitor by FTIR and UV-visible spectrophotometry techniques.

2. EXPERIMENTAL

2.1 Electrochemical tests

Electrochemical impedance and polarization measurements were achieved using frequency response analyzer (FRA) / potentiostat supplied from ACM instruments. The frequency range for electrochemical impedance spectroscopy (EIS) measurements was 0.1 to 1x10⁴ Hz with applied potential signal amplitude of 10 mV around the rest potential. The data were obtained in an electrochemical cell of three-electrode mode; platinum wire and saturated calomel electrode (SCE) were used as counter and reference electrodes. The materials used for constructing the working electrodes were steel, copper and zinc. The chemical composition of the working electrodes is given in table (1). The metal specimen was encapsulated in epoxy resin in such a way that only one surface was left uncovered. The samples were mechanically abraded with a series of emery papers of variable grades, starting with a coarse one and proceeding in steps to the finest (1000) grade. The samples were then washed thoroughly with double distilled water, followed with A. R. ethanol and finally with distilled water, just before insertion in the cell. Each experiment was carried out with newly polished electrode. Before polarization and EIS measurements, the working electrode was introduced into the test solution and left for 20 min to attain the open circuit potential. Polarization curve measurements were obtained at a scan rate of 20mV/min starting from cathodic potential (E_{corr} -250 mV) going to anodic direction until (E_{corr} +250 mV). All the measurements were done at 30.0 ± 0.1°C.

2.2 FT-IR

IR analysis was carried out using a TENSOR 37 Bruker model infra-red spectrophotometer. The samples were prepared by adding few drops of ethanolic solution of Azithromycin to aqueous solutions of Fe²⁺, Zn²⁺ and Cu²⁺ and left at room temperature until dryness and then mixed with KBr and then the IR test was performed.

2.3 UV-visible spectroscopy

The UV-Visible spectroscopy was carried out using Shimadzu UV 1800. The interaction of Azithromycin with Fe²⁺ ions was studied by the preparation of a series of methanolic water solutions (50 %: 50%) that contains a certain concentration of Fe²⁺ (1 x 10⁻⁴ M) and a variable concentration of Azithromycin in which the concentration of Azithromycin was varied in a way that makes the total ratio of Azithromycin to Fe²⁺ concentration ranged from 0 – 6 folds. The solution was allowed to stand for 15 minutes to equilibrate and the spectra were measured. The spectra were analyzed to determine the coordination number of the complexes formed.

2.4 Preparation of the solutions

The aqueous solution used was 0.5 M H₂SO₄ prepared from 5M H₂SO₄ diluted from analytical grade (Aldrich chemicals) concentrated acid 98% H₂SO₄ with doubly distilled water and was used without further purification. Solutions of different concentrations of Azithromycin were prepared by using double distilled water and the required volume of ethanol is added to obtain 10 % ethanol in the examined solutions. The chemical structure of Azithromycin is given in figure 1.

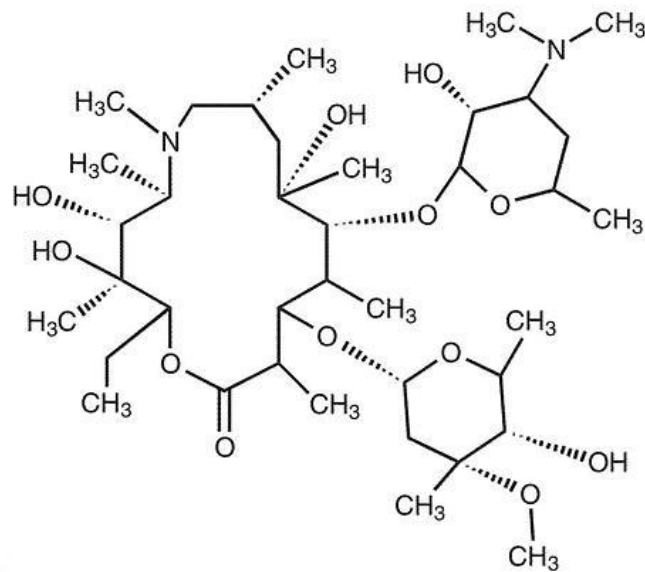

Figure 1. Chemical structure of Azithromycin

3. RESULTS AND DISCUSSION

3.1 Polarization measurements

Figure 2 shows the potentiodynamic polarization curve for mild steel in 0.5 M H₂SO₄ without and with the addition of various concentrations of Azithromycin.

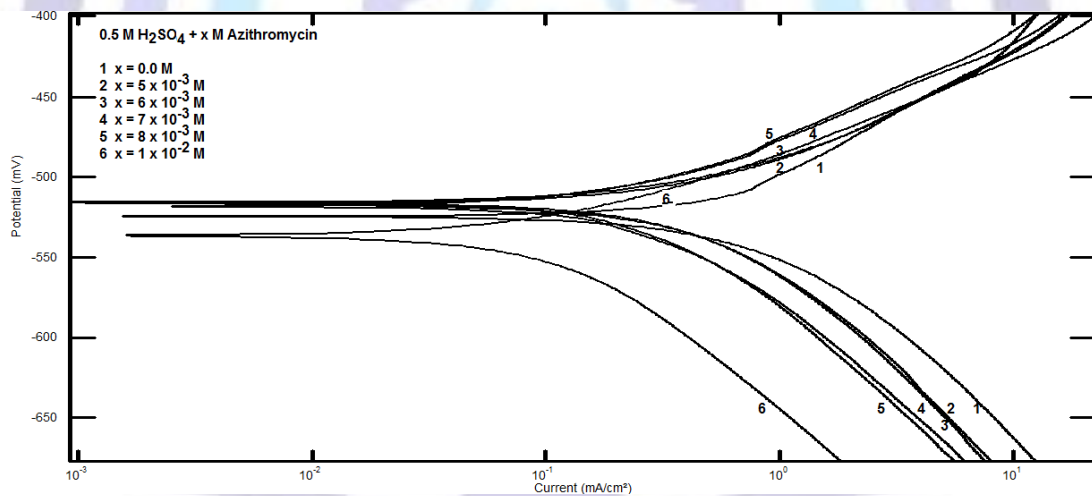

Figure 2. Potentiodynamic polarization curves of steel in 0.5 M H₂SO₄ in absence and presence of different concentrations of Azithromycin.

The figure shows that the presence of Azithromycin has effect on both the cathodic and anodic tafel lines indicating that Azithromycin act as mixed type inhibitor for steel in 0.5 M H₂SO₄. The potentiodynamic polarization parameters for mild steel in 0.5 M H₂SO₄ without and with the addition of various concentrations of Azithromycin derived from these curves and the inhibition efficiency % P which is calculated by the following equation:

$$\%P = \left[\frac{(i_{corr})_0 - i_{corr}}{(i_{corr})_0} \right] \times 100$$

are presented in table 2.



Table 2. Electrochemical polarization parameters for steel in 0.5 M H₂SO₄ in absence and presence of different concentrations of Azithromycin.

Conc. (mol/L)	-E _{corr} (mV)	β _a (mV/decade)	β _c (mV/decade)	i _{corr} (mA.cm ⁻²)	% P
0.0	516	78	108	0.595	--
5 x 10 ⁻³	520	75	115	0.481	19.2
6 x 10 ⁻³	521	75	116	0.472	20.6
7 x 10 ⁻³	513	67	115	0.277	53.4
8 x 10 ⁻³	512	62	115	0.267	55.1
1 x 10 ⁻²	539	59	113	0.119	80.0

From the data in table 2, it is clear that the corrosion current density decreases in presence of Azithromycin and decrease with increasing the concentration of Azithromycin. It is also seen in table 2 that both β_a and β_c are slightly changed in presence of Azithromycin indicated that the inhibitor affect both the cathodic and anodic reactions. It can be seen that the addition of Azithromycin do not alter the values of E_{corr} significantly indicating the mixed type of inhibition behavior of Azithromycin. Figures 3 and 4 represent the potentiodynamic polarization curves of zinc in 0.5 M H₂SO₄ in absence and presence of low and high concentrations of Azithromycin respectively.

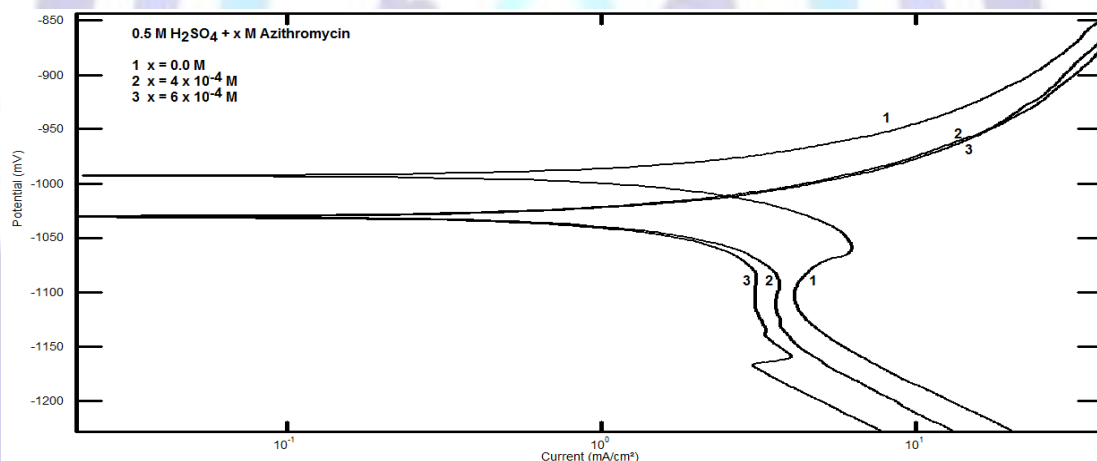

Figure 3. Potentiodynamic polarization curves of zinc in 0.5 M H₂SO₄ in absence and presence of low concentrations of Azithromycin.

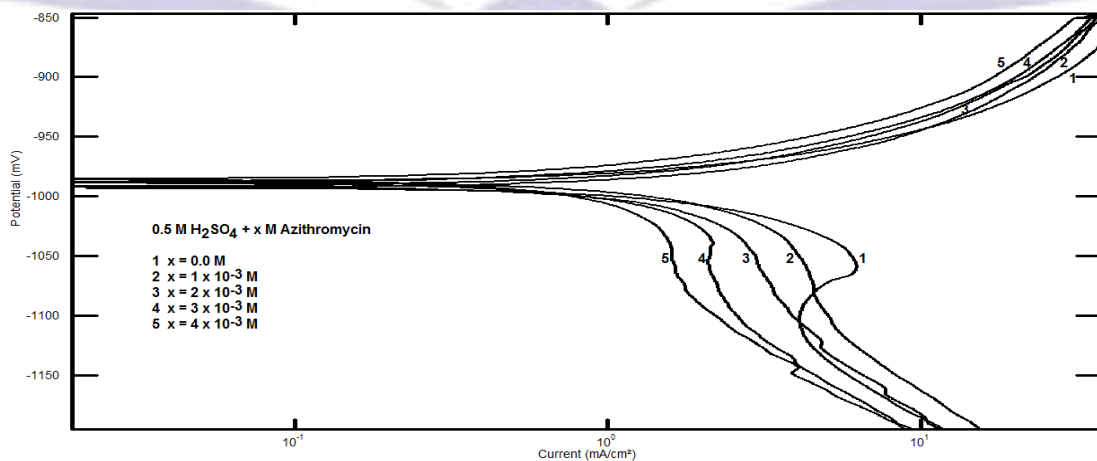
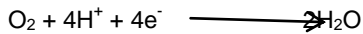
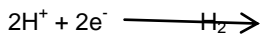

Figure 4. Potentiodynamic polarization curves of zinc in 0.5 M H₂SO₄ in absence and presence of high concentrations of Azithromycin.



It is clear that Azithromycin has predominated effect on the cathodic Tafel lines and almost has no effect on the anodic lines indicating that Azithromycin act as cathodic type inhibitor. The cathodic polarization curves indicated that more than one reduction reaction may occur on the surface, the first one is hydrogen reduction. The hydrogen atoms formed by reduction reaction at cathode adsorb on the surface of metal and remain there until removed by combination of two hydrogen atoms to form molecular hydrogen which is then released as a gas while the second is reaction with dissolved oxygen to form water.



The layer of adsorbed atomic hydrogen is said to polarize the cell. This type of polarization is called activation polarization and sometimes referred to as hydrogen polarization or cathodic polarization. Concentration polarization caused by concentration gradient of ions in solution which shield the metal thereby, causing a decrease in the potential of cell. In absence of oxygen (de-aerated), the first process applied until the adsorbed hydrogen atoms are removed from the metal surface, they effectively block the sites at which the last reaction occur and decrease the rate of corrosion. The cathodic polarization curves represented a system where, initially the reduction rate of hydrogen ions is under activation control, at higher reduction current it is controlled by concentration polarization at which oxygen reduction is mainly the cathodic reaction and limiting diffusion current density appears. Table 3 represents the change of limiting current with the concentration of Azithromycin. The variation of limiting current with the concentration of Azithromycin is represented in figure 5.

Table 3. Dependence of limiting current i_L on concentration of Azithromycin for zinc in 0.5 M H_2SO_4 .

Concentration (mol/L)	0.0	1×10^{-3}	2×10^{-3}	3×10^{-3}	4×10^{-3}
i_L (mA/cm ²)	6.28	4.15	3.03	2.11	1.58

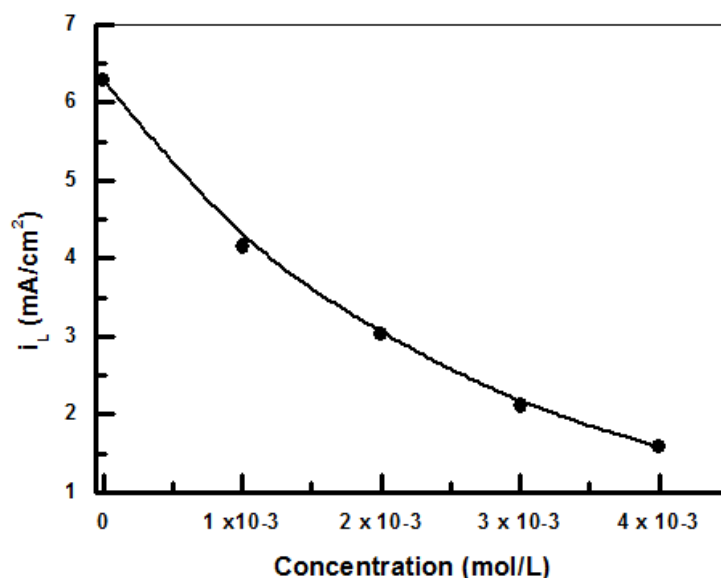

Figure 5. Dependence of limiting current i_L on concentration of Azithromycin for zinc in 0.5 M H_2SO_4 .

It is clear from figure 5 and table 3 that the limiting current decreases by increasing the concentration of Azithromycin. This can be explained on the basis that Azithromycin has the ability to adsorb and block the active dissolution sites on the electrode surface of Zn and act as effective inhibitor and consequently decreases the corrosion current. Figure 6 shows the potentiodynamic polarization curves of copper in 0.5 M H_2SO_4 in absence and presence of different concentrations of Azithromycin.

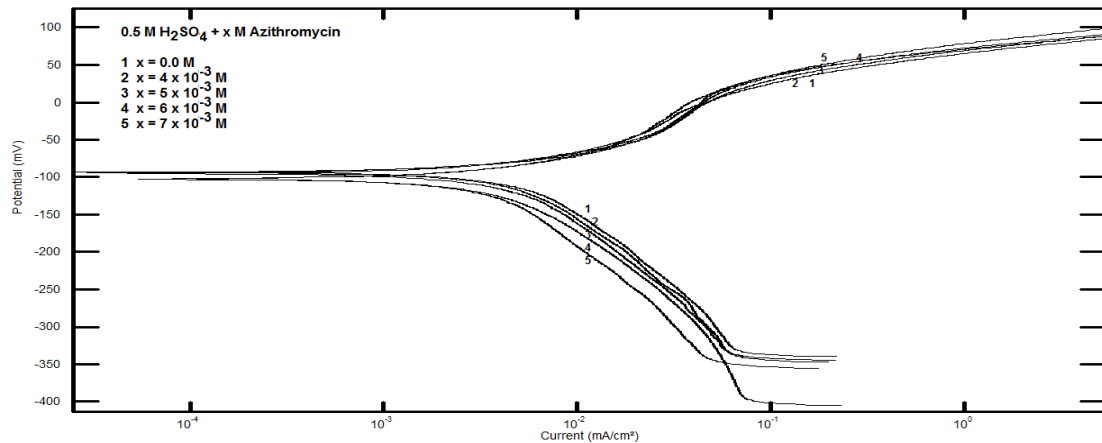
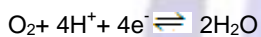
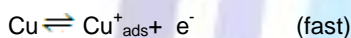

Figure 6. Potentiodynamic polarization curves of copper in 0.5 M H₂SO₄ in absence and presence of different concentrations of Azithromycin.

The cathodic parts of the polarization curves show limiting current corresponds to the oxygen reduction reaction that is slightly affected by the addition of Azithromycin. This indicates that the cathodic process is controlled by diffusion of oxygen gas from the bulk solution to the metal surface. This behavior is well known since copper can hardly be corroded in the deoxygenated dilute sulfuric acid [15], as copper cannot displace hydrogen from acid solutions according to the theories of chemical thermodynamics. However, in aerated sulfuric acid, dissolved oxygen is reduced on copper surface and this will enable some corrosion to take place [16]. Cathodic reduction of oxygen can be expressed either by two consecutive 2e⁻ steps involving a reduction to hydrogen peroxide first followed by a further reduction to water or by a direct 4e⁻ transfer step [17] as shown by the equation:



Addition of Azithromycin slightly affects the values of corrosion potential and shifts the corrosion current density to lower values indicating that this compound act as inhibitor. The anodic part of the polarization curves for copper in presence of Azithromycin shows (i) Tafel behavior indicating that the oxidation process is mainly controlled by charge transfer and (ii) inflection in the curve at about 0.00V which probably corresponds to the oxidation of Cu(I) to Cu(II). Since, it was reported that the anodic dissolution of copper in acidic solutions can be illustrated by the following two consecutive steps [18]:



It has been shown that in the Tafel extrapolation method, use of both the anodic and cathodic Tafel regions is undoubtedly preferred over the use of only one Tafel region [19]. The corrosion rate can also be determined by Tafel extrapolation of either the cathodic or anodic polarization curve alone. If only one polarization curve alone is used, it is generally the cathodic curve which usually produces a longer and better defined Tafel region. Anodic polarization may sometimes produce concentration effects, due to passivation and dissolution, as well as roughening of the surface which can lead to deviations from Tafel behavior [20]. The potentiodynamic polarization parameters for copper in 0.5 M H₂SO₄ without and with the addition of various concentrations of Azithromycin derived from these curves and the inhibition efficiency % P are presented in table 4.

Table 4. Electrochemical polarization parameters copper in 0.5 M H₂SO₄ in absence and presence of different concentrations of Azithromycin.

Conc. (mol/L)	- E _{corr} (mV)	β _a (mV/decade)	β _c (mV/decade)	i _{corr} (mA.cm ⁻²)	% P
0.0	79	87.5	219	0.0078	--
4 x 10 ⁻³	139	183	169	0.0075	3.8
5 x 10 ⁻³	115	125	182	0.0067	14.1
6 x 10 ⁻³	122	154	179	0.0066	15.4
7 x 10 ⁻³	108	114	191	0.0063	19.2
8 x 10 ⁻³	130	128	148	0.0051	34.6
9 x 10 ⁻³	126	127	202	0.0046	41.0

From the data in the table the corrosion current density decreases with increasing the concentration of inhibitor indicating the inhibition behavior of Azithromycin.

3.2 electrochemical impedance spectroscopy

Figures 7-9 represent Nyquist plots for steel, zinc and copper in 0.5 M H₂SO₄ in absence and presence of different concentrations of Azithromycin.

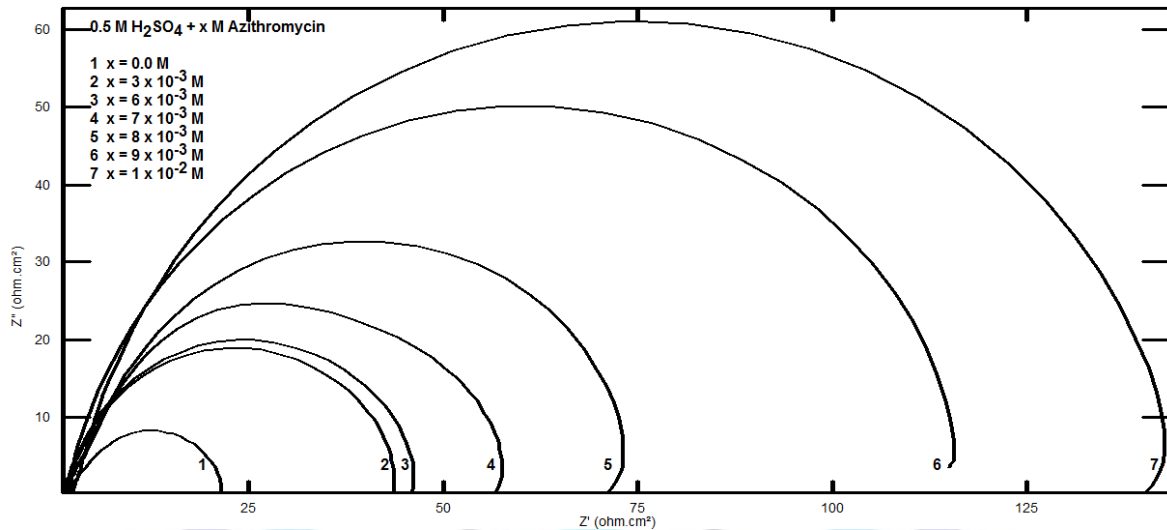

Figure 7. Nyquist plots of steel in 0.5 M H₂SO₄ in absence and presence of different concentrations of Azithromycin.

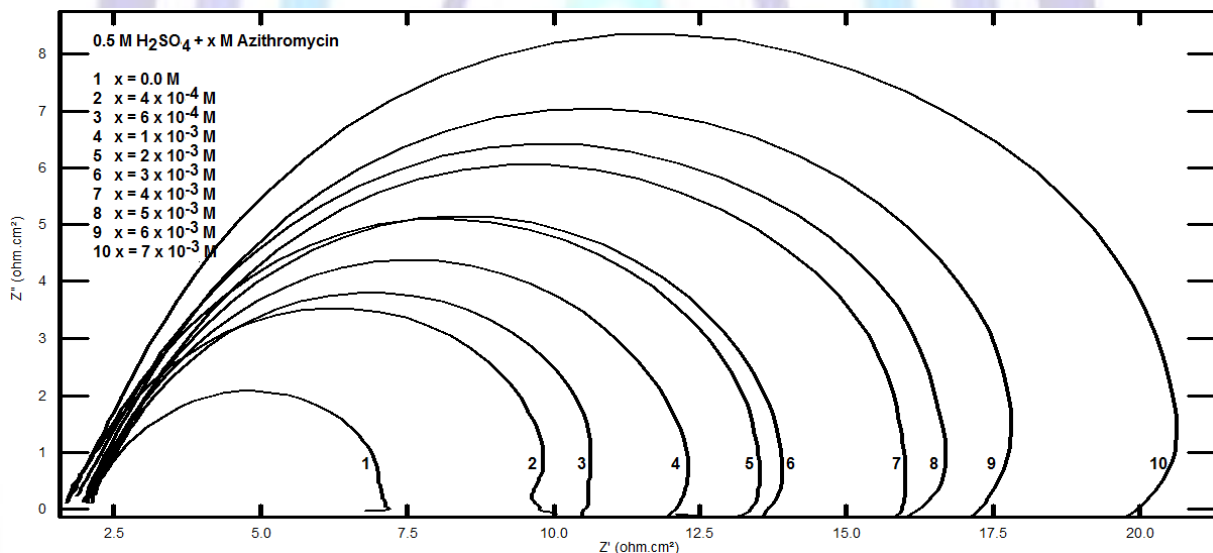

Figure 8. Nyquist plots of zinc in 0.5 M H₂SO₄ in absence and presence of different concentrations of Azithromycin.

The influence of Azithromycin on the Nyquist plots of steel and zinc in 0.5 M H₂SO₄ solution manifested only one depressed capacitive semicircle. The diameter of the semicircle increases with increasing the extract concentration. The impedance spectra for different Nyquist plots were analyzed by fitting the experimental data using Zsimpwin program to a simple equivalent circuit model represented in figure 9a. The equivalent circuit model includes the solution resistance R_s and the double layer capacitance C_{dl} which is placed in parallel to the charge transfer resistance element R_{ct}.

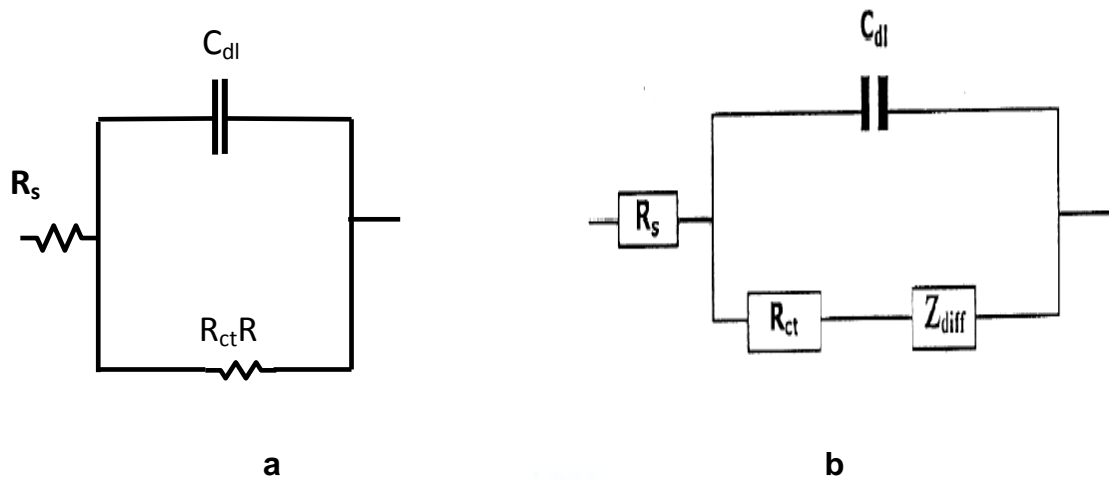

Figure 9. Equivalent Circuits

The values of the electrochemical parameters and the inhibition efficiency (% P) obtained from EIS steel and zinc in 0.5 M H₂SO₄ solutions containing different Azithromycin concentrations are given in tables 5 and 6. The inhibition efficiency was calculated from impedance measurements using the relation:

$$\% P = [(R_{ct} - R_{ct0}) / R_{ct}] \times 100$$

Where; R_{ct0} and R_{ct} are the charge transfer resistances in the absence and presence of different Azithromycin concentrations.

The results show that, R_{ct} values for steel and zinc increase with increasing the Azithromycin concentration. The increase of R_{ct} values suggest the formation of a protective layer on the electrode surface. This layer acts as a barrier for mass and charge transfer [21-23]. The capacitance of the double layer C_{dl} decreases with increasing the concentration of the inhibitor; this can be explained due to the adsorption of inhibitor on to the steel and zinc surface.

Table 5: The values of the impedance parameters for steel in 0.5 M H₂SO₄ solution in the absence and presence of different concentrations of Azithromycin at 30 °C.

Conc. (ppm)	R _s (Ohm.cm ²)	C _{dl} (μF.cm ⁻¹)	R _{ct} (Ohm.cm ²)	% P
0.0	2.4	3.1 x 10 ⁻⁴	19.5	----
1 x 10 ⁻³	1.8	1.3 x 10 ⁻⁴	43.5	55.1
3 x 10 ⁻³	1.6	1.1 x 10 ⁻⁴	43.8	56.0
5 x 10 ⁻³	1.4	1.1 x 10 ⁻⁴	44.9	56.5
6 x 10 ⁻³	1.3	1.1 x 10 ⁻⁴	46.0	57.6
7 x 10 ⁻³	2.0	1.1 x 10 ⁻⁴	56.4	65.4
8 x 10 ⁻³	2.0	9.9 x 10 ⁻⁵	73.4	73.5
9 x 10 ⁻³	1.1	7.0 x 10 ⁻⁵	119.9	83.7
1 x 10 ⁻²	2.6	8.4 x 10 ⁻⁵	144.6	86.8



Table 6. The values of the impedance parameters for zinc in 0.5 M H₂SO₄ solution in the absence and presence of different concentrations of Azithromycin at 30 °C.

Conc. (ppm)	R _s (Ohm.cm ²)	C _{dl} (μF.cm ⁻¹)	R _{ct} (Ohm.cm ²)	% P
0.0	1.9	2.3 x 10 ⁻⁴	5.6	----
4 x 10 ⁻⁴	1.7	1.4 x 10 ⁻⁴	8.9	37.1
6 x 10 ⁻⁴	2.1	1.1 x 10 ⁻⁴	9.5	41.0
1 x 10 ⁻³	2.0	1.2 x 10 ⁻⁴	10.9	48.6
2 x 10 ⁻³	1.7	8.0 x 10 ⁻⁵	12.5	55.2
3 x 10 ⁻³	2.1	6.9 x 10 ⁻⁵	14.7	61.9
4 x 10 ⁻³	1.9	7.8 x 10 ⁻⁵	15.8	64.5
5 x 10 ⁻³	2.0	7.5 x 10 ⁻⁵	16.9	66.8
6 x 10 ⁻³	1.8	5.3 x 10 ⁻⁵	19.6	71.4
7 x 10 ⁻³	1.7	4.5 x 10 ⁻⁵	20.9	73.2

Figure 10 shows Nyquist plots for copper in 0.5 M H₂SO₄ solution containing different concentrations of Azithromycin.

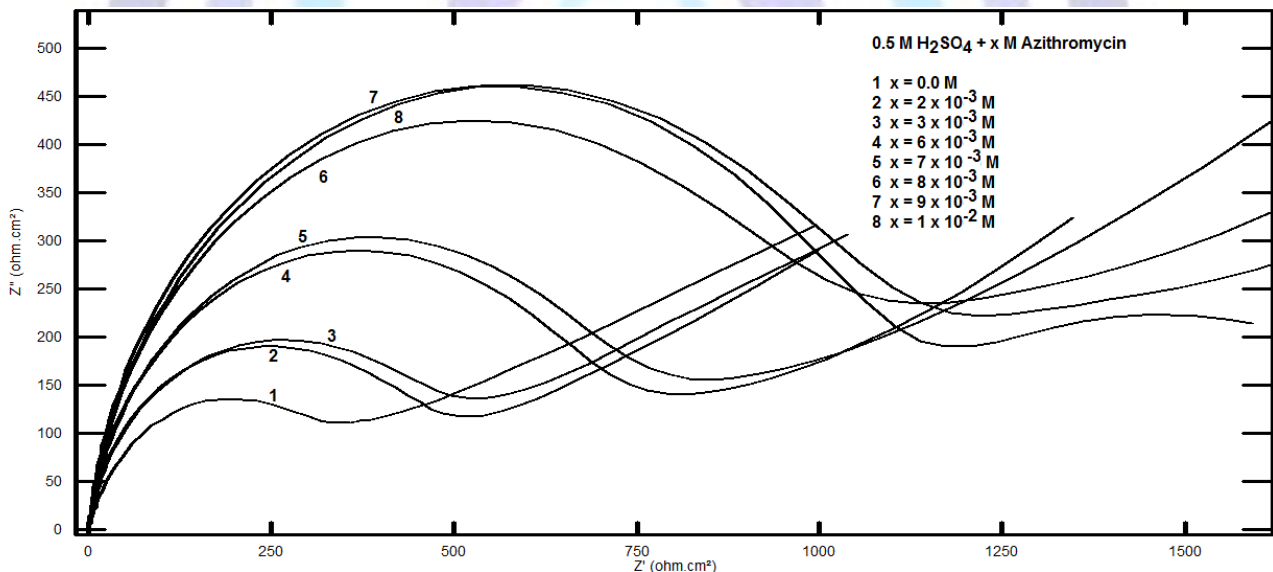

Figure 10. Nyquist plots of copper in 0.5 M H₂SO₄ in absence and presence of different concentrations of Azithromycin.

The plots are characterized by the presence of a semi-circle in the high frequencies region followed by a line inclined at a certain angle to the real axis in the low frequencies. The high frequency semi-circle is associated with the charge transfer process, whose diameter corresponds to the charge transfer resistance. In the case of line at low frequencies, it can be concluded that it corresponds to a mass transfer phenomenon since the angle of the line observed in the low frequencies with the real axis is close to 45°, forming a typical Warburg tail [24-25]. As a result, it could be concluded that the corrosion of copper in 0.5 M H₂SO₄ solution is controlled by diffusion. The obtained experimental data were fitted to the equivalent circuit shown in figure 9b by using Zsimpwin program. The equivalent circuit model includes solution resistance, R_s, charge transfer resistance R_{ct}, double layer capacitance C_{dl} and Warburg diffusion element Z_{diff}. The electrochemical impedance parameters obtained from fitting are given in table 7. It is clear that, the R_{ct} values increase with increasing the Azithromycin concentration indicating that Azithromycin inhibits the dissolution of copper in acid medium. The decrease in the values of the double layer capacitance C_{dl} with increasing Azithromycin concentration indicates that the inhibition process occurs through adsorption mechanism.



Table 7. The values of the impedance parameters for copper in 0.5 M H₂SO₄ solution in the absence and presence of different concentrations of Azithromycin at 30 °C.

Conc. (ppm)	R _s (Ohm.cm ²)	C _{dl} (μF.cm ⁻¹)	R _{ct} (Ohm.cm ²)	% P	Z _{diff}
0.0	1.4	1.2 x 10 ⁻⁴	378.3	----	3.86 x 10 ⁻³
2 x 10 ⁻³	8.3	7.2 x 10 ⁻⁵	514.5	26.5	3.59 x 10 ⁻³
3 x 10 ⁻³	5.2	9.2 x 10 ⁻⁵	541.7	30.2	3.92 x 10 ⁻³
4 x 10 ⁻³	5.1	1.4 x 10 ⁻⁴	577.9	34.5	3.83 x 10 ⁻³
5 x 10 ⁻³	1.1	1.0 x 10 ⁻⁴	592.5	36.2	3.79 x 10 ⁻³
6 x 10 ⁻³	4.7	5.5 x 10 ⁻⁵	768.1	50.7	3.72 x 10 ⁻³
7 x 10 ⁻³	9.1	5.6 x 10 ⁻⁵	801.2	52.8	3.16 x 10 ⁻³
8 x 10 ⁻³	5.5	5.4 x 10 ⁻⁵	1092	65.4	2.70 x 10 ⁻³
9 x 10 ⁻³	1.1	3.2 x 10 ⁻⁵	1118	66.1	2.86 x 10 ⁻³
1 x 10 ⁻²	4.9	4.0 x 10 ⁻⁵	1167	67.6	2.80 x 10 ⁻³

3.3. Application of Adsorption Isotherm

The nature of the adsorption process of the Azithromycin on the different metals surface was essential to our knowledge of their inhibition action to corrosion. The variation of percentage inhibition with concentration of Azithromycin was shown in figure 11. This plot is characterized by an initial steeply rising part indicating the formation of a mono-layer adsorbate film on the aluminum surface. At high concentrations, the inhibitory effect was constant suggesting complete saturation of the surface by the inhibitor molecules. The action of adsorptive inhibitors was studied by El-Awady et al [26] under pseudo zero order conditions and the mathematical expression were given as:

$$\log [\theta / (1-\theta)] = \log K' + y \log [I]$$

Where; θ is the degree of surface coverage by inhibitor, $(1-\theta)$ is the fraction of the surface available for medium attack, y is the number of inhibitor molecules occupying one active site.

The value, $1/y$ represents the number of active sites of the surface occupied by one inhibitor molecule. Value of $1/y$ less than unity implies the formation of multilayer of the inhibitor on the surface of the metal. However, values of $1/y$ greater than unity indicate that a given inhibitor molecule will occupy more than one active site [27]. The binding constant K corresponding to that obtained from the adsorption isotherm curve fitting is given by:

$$K = K' (1/y)$$

Figure 12 shows the application of the Kinetic-Thermodynamic model to the results of adsorption of Azithromycin on steel, zinc and copper surface. The Kinetic-Thermodynamic model was found to fit the data of Azithromycin in 0.5 M H₂SO₄ solution on steel, zinc and copper surface and the linear fitting parameters are given in table 8.

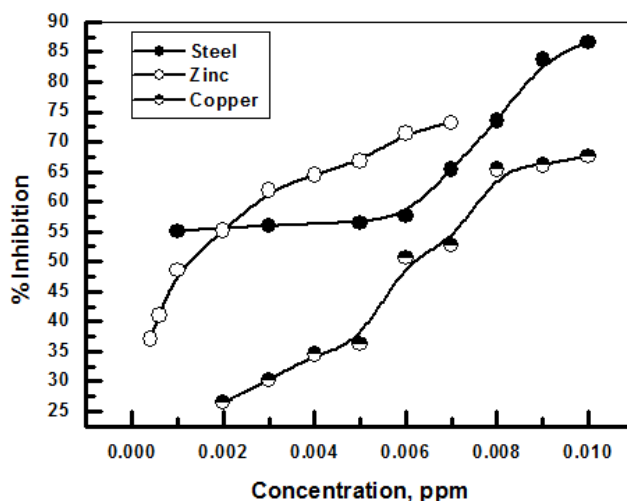

Figure 11: Variations of the percentage inhibition of Azithromycin on steel, zinc and copper in 0.5 M H₂SO₄ solution.

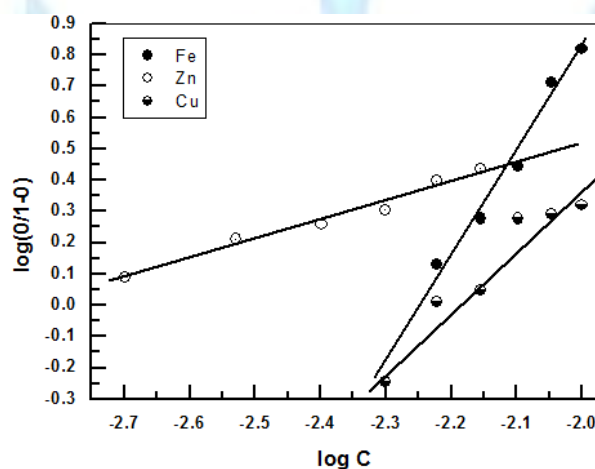

Figure 12: Application of Kinetic-Thermodynamic model to the results of adsorption of Azithromycin in 0.5 M H₂SO₄ solution on steel, zinc and copper surface.

Table 8. Linear fitting parameters of Azithromycin according to the Kinetic Thermodynamic model for 0.5 M H₂SO₄ solution on steel, zinc and copper surface.

Metal	Model parameters	
	Kinetic-Thermodynamic	
	1/y	K
Fe	0.31	0.266
Zn	1.61	0.395
Cu	0.83	0.358

The number of active sites occupied by a single inhibitor molecule, $1/y$ were nearly equal one for copper indicating that each inhibitor molecule can occupy only one active site on the copper surface while, $1/y$ were more than one for zinc indicating that each inhibitor molecule can occupy more than one active site on the zinc surface. while, $1/y$ were less than one for steel indicating that more than one inhibitor molecule can occupy one active site on the steel surface. The low values of K indicate that there is a weak adsorption of the Azithromycin on the metal surface.

3.4. FT-IR Analysis

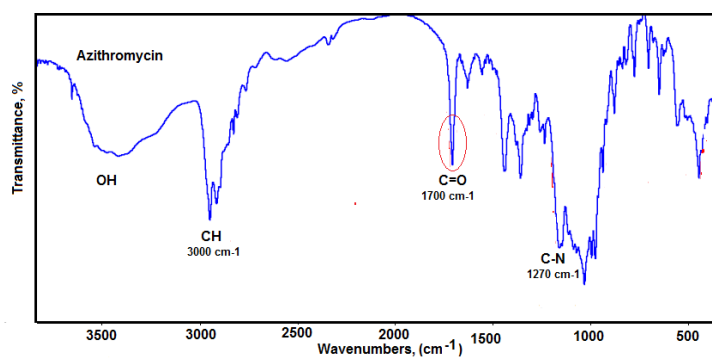

A

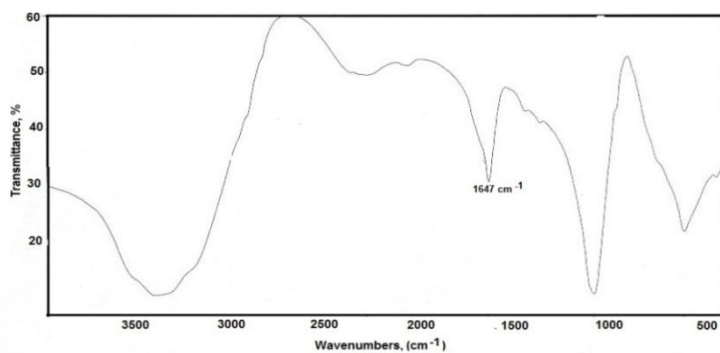

B

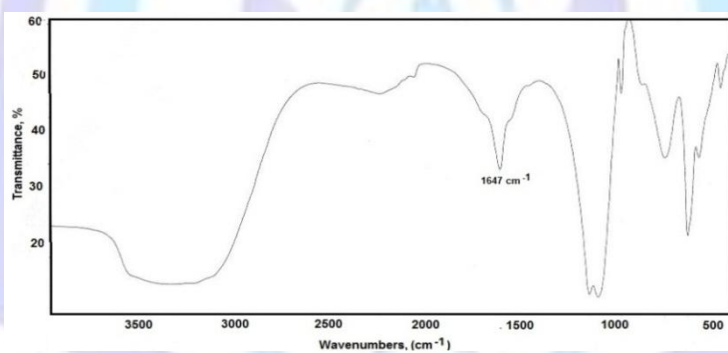

C

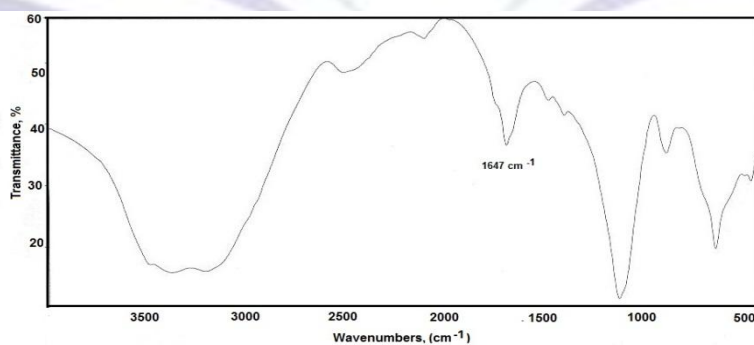

D

Figure 13. FT-IR spectra. a) solid Azithromycin b) Fe^{2+} -Azithromycin complex prepared c) Zn^{2+} -Azithromycin complex prepared d) Cu^{2+} -Azithromycin complex prepared

In order to further support the adsorption behavior of the inhibitor on the metal surface IR spectroscopy was performed [28-29]. Figure 13 shows the IR spectrum of ethanolic solution of Azithromycin in absence and presence of metal ions. It can be seen that the inhibitor exhibited a broad band at 3400 cm^{-1} indicating the presence of OH, sharp band at 3000 cm^{-1} indicating the presence of CH bond, peak at 1270 cm^{-1} indicating the C—N bond and a sharp peak at 1700 cm^{-1} indicating the presence of C=O. In presence of metal ions the strong peak at 1700 cm^{-1} of C=O disappeared confirming the formation of M^{2+} - complex on the anodic sites of the metal surface and the adsorption of the inhibitor onto the metal surface at the C=O.

3.5. Explanation for inhibition

The inhibitor molecules adsorbed over the metal surface blocking the active sites in which direct acid attack causes corrosion thereby protecting the metal from corrosion. The structure of Azithromycin have an oxygen heteroatom and C=O in its structure, thus inhibition of the corrosion of metal by Azithromycin may be attributed to the adsorption of the extract components through the C=O center, which is regarded as center of adsorption onto the metal surface. While adsorbed they create a barrier to mass and charge transfer and thus isolate the metal from further attack of the corrosive anions [30-31]. The inhibitor may then combine with freshly generated M^{2+} ions on the metal surface, forming metal-inhibitor complex:

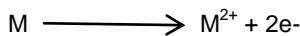

The resulting complex could, depending on its relative solubility, either inhibit or catalyze further metal dissolution; hence the integrity depends on the environments capacity to dilute it. The results obtained so far suggest that Azithromycin exhibited good inhibition efficiency during metal corrosion in $0.5\text{ M H}_2\text{SO}_4$ solution. The adsorption of inhibitor on the metal surface reduces the surface area available for corrosion.

3.6 UV-Visible Spectrophotometry

Figure 14 represents the spectra of a series of solutions of fixed concentration of ferrous ion in which the ratio of Azithromycin to Fe^{2+} concentration ratio was varied between 0 – 6 folds. It can be seen that increasing Azithromycin to Fe^{2+} concentration ratio causes an increase in the absorbance at all wave lengths. However, the absorbance increase starts to level off when the Azithromycin to Fe^{2+} total concentration reaches a certain point indicating that it is caused by the reaction between Azithromycin and the Fe^{2+} ions. It can be seen that increasing the Azithromycin concentration causes an increase in absorbance at all the wavelengths until the concentration ratio of 1:1 is reached. After reaching this ratio the absorbance remains constant. This behavior is indicative of the formation of only one complex with molar ratio of 1:1[32].

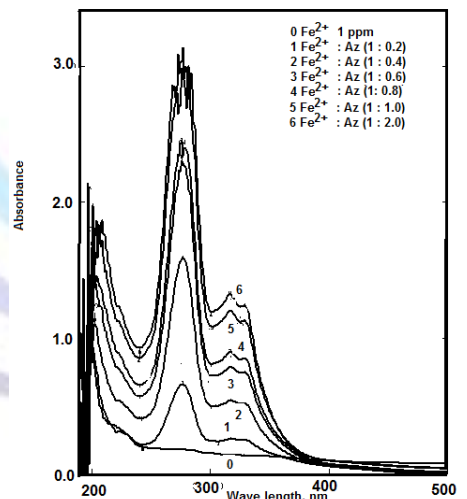

Figure 14. UV-Visible spectroscopy of a series of water methanolic solutions containing a fixed concentration of Fe^{2+} ($1 \times 10^{-4}\text{ M}$) and a varying concentration of Azithromycin

4. CONCLUSIONS

- The potentiodynamic polarization results showed that Azithromycin is mixed type inhibitor for steel in $0.5\text{ M H}_2\text{SO}_4$ and cathodic type in case of zinc. The polarization curves showed that more than one reduction reaction occur which are the hydrogen ion reduction and oxygen reduction.
- The cathodic polarization curves for copper in presence of Azithromycin in $0.5\text{ M H}_2\text{SO}_4$ showed limiting current corresponds to the oxygen reduction control.
- The impedance results for steel and zinc in $0.5\text{ M H}_2\text{SO}_4$ in presence of Azithromycin show that the charge transfer resistance increase with increasing the concentration of Azithromycin suggesting the formation of protective layer on



the electrode surface.

- The impedance results conclude that the corrosion of copper in H₂SO₄ is controlled by diffusion.
- The low values of the binding constant indicating the weak adsorption of Azithromycin on the metal surface.
- FT-IR analysis shows the disappearance of C=O peak in presence of Azithromycin indicate the formation of M²⁺--- complex on the anodic surface and the adsorption of inhibitor at the C=O bond.
- UV-visible spectrophotometry indicate the formation of only one complex with molar ratio of 1:1

REFERENCES

- [1] Gece G, 53(2011) Corros. Sci.:3873-3898.
- [2] Hausler R, (1979) Corrosion Chemistry, ACS Symposium Series, American Chemical Society, Washington, DC :p262-320.
- [3] LeceH D, Emergul, K C, Atakol O, 50(2008) Corros. Sci.: 1460-1478.
- [4] Mu G, Li X, Qu Q, Zhou J, 48(2006) Corros. Sci.:445-459.
- [5] Samiento E, Gonzalez J G, Uruchurtu J, Dominguez G, Salinas V M, 50(2008) Corros Sci.:2296-2303.
- [6] Bastos A C, Ferreira M G, Simdes A M, 48(2006) Corros. Sci.:1500-1512.
- [7] Sahin M, Gece G, Karci F, Bilgic S, 38(2008) J. Appl. Electrochem.: 809- 815.
- [8] Gece G, 50(2008) Corros. Sci.:2981-2992.
- [9] Struck S, Schmidt U, Gruening B, Jaeger J S, Hossbach J, Preissner R,20(2008) Genome Inform.:231-242.
- [10] Enick O V, (2006) Thessis, Simon Fraser University, Burnaby.
- [11] Acharya S, Upadhyay S N, 57(2004)Trans. Indian Inst. Met.:297-306.
- [12] Eddy N O, Stoyanov S R, Ebenso E E, 5(2010) Int. J. Electrochem. Sci.: 1127-1150 .
- [13] Shukla S K, Quraishi M A, 51(2009) Corros. Sci.:1007-1011.
- [14] Xuehui P, 69(2011) ActaChim. Sinica :483-491.
- [15] Ma H, Chen Sh, Yin B, Zhao Sh, Liu X, 45(2003)J.Corros. Sci.: 867-882.
- [16] Moreira A H, Benedetti A V, Calot P L, Sumodja P T A, 38 (1993) Electrochim. Acta.:981-987.
- [17] Jinturkar P, Guan Y C, Han K N, 54(1984)Corrosion :106-114.
- [18] Wang D K Y, Coller B A W, Macfarlane D R, 38(1993)Electrochim. Acta : 2121-2127 . McCafferty E, 47(2005) J Corros. Sci.:3202-3215.
- [19] Caban R, Chapman T W, 124(1977)J. Electrochem. Soc.:1371-1379.
- [20] Shreir L L, Jarman R A, Burstein G T, 1(2000) CORROSION, Metal/Environment Reactions, Butterworth-Heinemann, Oxford, 3rd edition :p1-18.
- [21] Afak S S, 54 (2012) Corros. Sci.:251-259.
- [22] Khaled K F, 112 (2008) Mater. Chem. Phys.: 290-300.
- [23] Behpour M, Ghoreishi S M, Mohammadi N, Soltani N, Salavati-Niasari M, 52 (2010) Corros. Sci. : 4046-4057.
- [24] Liu Z, Huang B, GU M, 60(2006) Materials Letters :2024-2028.
- [25] Marchebois H, Savall C, Bernard J, Touzain S, 49(2004) Electrochim. Acta : 2945-2954.
- [26] El-Awady A, Abd El-Nabey B A, Aziz G, 139 (1992) Electrochem. Soc.:2149-2154.
- [27] El-Awady A, Abd El-Nabey B.A, Aziz G, Khalifa M, Al-Ghanedy H A, (1990) Int. J. Chem.: 1169-1179.
- [28] Odiongenyi O, Odoemelum S A, Eddy N O, 27(2009) PortugalliaeElectrochimicaActa :33-45.
- [29] Arockia J, Rajendran S, Ganga V, Amalraj A J, Narayanasamy B, 27(2009) PortugalliaeElectrochimicaActa :1-11.
- [30] Okafor P C, Ikpi M E, Uwah I E, Ebenso E E, Ekpe U J, Umoren S A, 50(2008)Corros. Sci.: 2310-2317.
- [31]Eduke U M, Etim U J, Akpakan A E, Umoren S A, 1(2012) Int. j. Adv.Sci. Res. and Tech.: 338-360.
- [32]El-Rjoob A, Al-Mustafa J, Taha Z, Abous M, 3(2008) Jord. j. Chem.:199-209.