



ELEVEN LEVEL INVERTER DESIGN WITH DVR FOR DISTRIBUTION ENERGY SYSTEM

SACHINAMREISS.GN¹, DINESHKUMAR.S²

ASSISTANT PROFESSOR,EEE DEPARTMENT ,M.KUMARASAMY COLLEGE OF ENGINEERING
sachinamreissgn.eee@mkce.ac.in

ASSISTANT PROFESSOR,EEE DEPARTMENT ,M.KUMARASAMY COLLEGE OF ENGINEERING
dineshkumars.eee@mkce.ac.in , dhineshselvaraj@gmail.com

ABSTRACT

In this paper with flexible AC transmission system capability is implemented. The proposed inverter is placed between the wind turbine and the grid, same as a regular WEI, and is able to regulate active and reactive power transferred to the grid. This inverter is equipped with dynamic voltage restorer option in order to control the power factor of the local feeder lines. The goal of this project is to introduce new ways to increase the penetration of renewable energy systems into the distribution systems. This will encourage the utilities and customers to act not only as a consumer, but also as a supplier of energy.

Key words:Modular multilevel converter (MMC), multilevel inverter (MLI), wind energy inverter (WEI).

1 INTRODUCTION

The power electronic devices due to their inherent nonlinearity draw harmonic and reactive power from the supply. In three phase systems, they could also cause unbalance and draw excessive neutral currents. The injected harmonics, reactive power unbalance, and excessive neutral currents cause low system efficiency and poor power factor. The use of the sophisticated equipment/loads at transmission and distribution level has increased considerably in recent years due to the development in the semiconductor device technology. The equipment needs clean power in order to function properly. At the same time, the switching operation of these devices generates current harmonics resulting in a polluted distribution system. The power-electronics-based devices have been used to overcome the major power quality problems.

All the non-linear loads draw highly distorted currents from the utility system, with their third harmonics component almost as large as the fundamental[1]. The increasing use of non-linear loads, accompanied by an increase in associated problems concerns both electrical utilities and utility customer alike. The power quality is improved by the use of implementation of DVR.DVR is one of the major custom power devices, capable of mitigating the effect of power quality problem. In existing system DSTATCOM is used[2-4]. DSTATCOM can compensate almost all power quality problems such as:

- Voltage harmonics, voltage unbalance,
- Voltage flickers, voltage sags, voltage swells,
- Current harmonics, current unbalance, etc

Dynamic Voltage Restorer used for the voltage harmonic compensation and it gives a high impedance path to the harmonic currents voltage. In proposed system dynamic voltage restorer with eleven inverter is used and it has the capability of improving power quality at the point of installation and also on power distribution systems [5,6].The DVR, therefore, is expected to be one of the most powerful solutions to large capacity loads sensitive to supply voltage flicker/imbalance.

II.EXISTING SYSTEM

A. Introduction

A new single-phase wind energy inverter (WEI) with flexible AC transmission system (FACTS) capability is presented. The proposed inverter is placed between the wind turbine and the grid, same as a regular WEI, and is able to regulate active and reactive power transferred to the grid.[8]

The power electronic devices are usually used to convert the nonconventional forms of energy to the suitable energy for power grids, in terms of voltage and frequency. In permanent magnet (PM) wind applications, a back-to-back converter is normally utilized to connect the generator to the grid.[7]

The existing control strategy regulates the active and reactive power using power angle and modulation index, respectively. The function of the proposed inverter is to transfer active power to the grid as well as keeping the PF of the local power lines constant at a target PF regardless of the incoming active power from the wind turbine.

Reactive power is regulated and transferred under any one of this method.[9]



Voltage control
Current control
Phase angle control

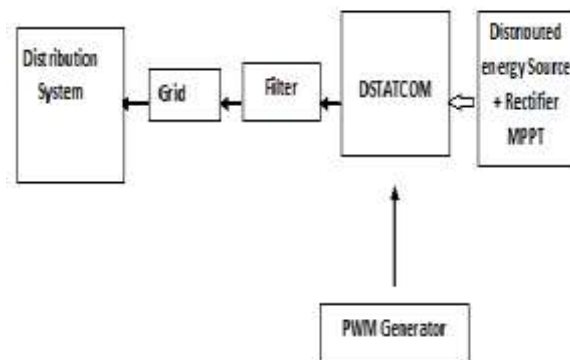

Fig 1 Block diagram of existing system

B..Disadvantages of existing system

Output current and voltage having significant fluctuation.

III.PROPOSED SYSTEM

The power quality in distribution system is affected pollution introduced by the customers. It is necessary to protect the sensitive loads from disturbances such as sags, swells, source of voltage imbalances. The actual solution for this case is to employ a dynamic voltage restorer.

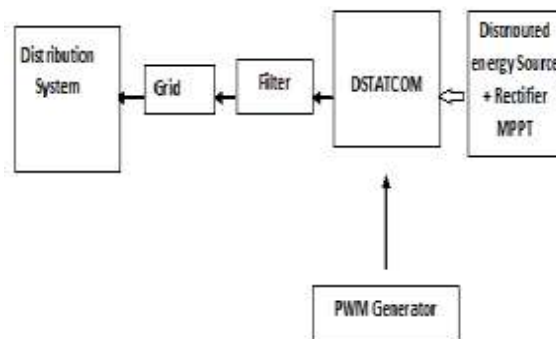

Fig 2 Block Diagram Representation of the Proposed System

A rectifier is an electrical device that converts Alternating Current (AC) which periodically reverses direction, to Direct Current (DC), which flows in only one direction. The process is known as rectification. Physically, rectifiers take a number of forms, including vacuum tube diodes, mercury-arc valves, copper and selenium oxide rectifiers, semiconductor diodes, silicon-controlled rectifiers and other silicon-based semiconductor switches. Rectification may serve in roles other than to generate direct current for use as a source of power.

Maximum power point tracking (MPPT) is a technique that grid connected inverters, solar battery chargers and similar devices use to get the maximum possible power from one or more photovoltaic devices, typically solar panels, though optical power transmission systems can benefit from similar technology. Solar cells have a complex relationship between solar irradiation, temperature and total resistance that produces a non-linear output efficiency which can be analyzed based on the I-V curve. It is the purpose of the MPPT system to sample the output of the cells and apply the proper resistance (load) to obtain maximum power for any given environmental conditions. MPPT devices are typically integrated into an electric power converter system that provides voltage or current conversion, filtering, and regulation for driving various loads, including power grids, batteries, or motors.[10]

DVR is a series compensation device that it performs the function such as Protect critical loads from all supply sides disturbances other than outages. DVR is a capable of generating or absorbing independently controllable real and

reactive power at its ac output terminal. DVR is a DC to AC switching power converter.[11]

The average value of voltage fed to the load is controlled by turning the switch between supply and load on and off at a fast pace. The longer the switch is on compared to the off periods, the higher the power supplied to the load.

A. Basic principle of DVR

DVR is to inject a voltage of required magnitude and frequency. So that it can restore the load side voltage to the desired amplitude and waveform even when the source voltage is unbalanced

Among the power quality problems such as sags, swells, harmonics are the most severe disturbances. In order to overcome these problems the concept of custom power devices is introduced recently. One of those devices is the Dynamic Voltage Restorer, which is the most efficient and effective modern custom power device used in power distribution networks.

DVR is a recently proposed series connected solid state device that injects voltage into the system in order to regulate the load side voltage. It is normally installed in a distribution system between the supply and the critical load feeder at the point of common coupling. Other than voltage sags and swells compensation, DVR can also added other features like: line voltage harmonics compensation, reduction of transients in voltage and fault current limitations. Power is injected and restores the load side voltage.

B. Circuit diagram

DVR is placed in-between the distributed system and grid. Wind turbine generates the power and rectifier converts ac to dc. Maximum power point tracking is a technique that grid connected inverters, wind turbines and similar devices use to get the maximum possible power from rotor device, typically wind turbine, though optical power transmission systems can benefit from similar technology. Wind energy have a complex relationship between turbine, wind and total resistance that produces a non-linear output efficiency .

The most important aspect which sets the cascaded H Bridge apart from other multilevel inverters is the capability of utilizing different DC voltages on the individual H bridge cells. In two level PWM, the switching frequency is always equal to the carrier frequency for modulation indices less than unity

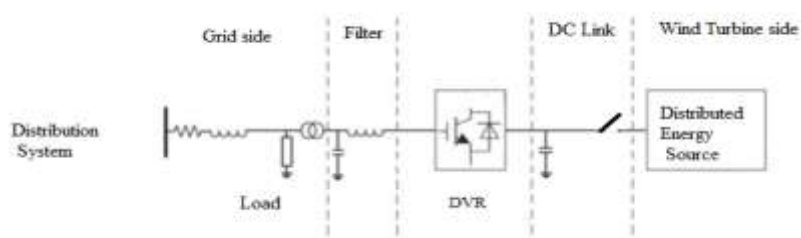

Fig 3. Circuit Diagram of Proposed System

Wind turbine has a complex relationship between their operating environment and the maximum power they can produce. The fill factor, abbreviated FF, is a parameter which characterizes the non-linear electrical behavior of the wind. Fill factor is defined as the ratio of the maximum power from the wind turbine to the product of Open Circuit Voltage V_{oc} and Short-Circuit Current I_{sc} .

In data it is often used to estimate the maximum power that a cell can provide with an optimal load under given conditions, $P = FF \cdot V_{oc} \cdot I_{sc}$. For most purposes, FF, V_{oc} , and I_{sc} are enough information to give a useful approximate model of the electrical behaviour of a photovoltaic cell under typical conditions.

For any given set of operational conditions, wind have a single operating point where the values of the current (I) and Voltage (V) of the cell result in a maximum power output. These values correspond to a particular load resistance, which is equal to V / I as specified by Ohm's Law. The power P is given by $P = V \cdot I$. A wind turbine, for the majority of its useful curve, acts as a constant current source. However, at a wind speed MPP region, its curve has an approximately inverse exponential relationship between current and voltage. From basic circuit theory, the power delivered from or to a device is optimized where the derivative (graphically, the slope) dI/dV of the I-V curve is equal and opposite the I/V ratio (where $dP/dV = 0$). This is known as the maximum power point and corresponds to the "knee" of the curve.

C. Cascaded multilevel inverters

A relatively new power converter structure, cascaded-inverters with separate DC sources is introduced here. This new converter can avoid extra clamping diodes or voltage balancing capacitors. Figure 3.3 shows the basic structure of the cascaded inverters with SDC for three phase configuration. Each SDC is associated with a single phase full bridge inverter. The AC terminal voltages of different level inverters are connected in series. The phase output voltage is synthesized by the sum of four inverter outputs. Each single-phase full bridge inverter can generate three level outputs,

+Vdc, 0, and -Vdc. This is made possible by connecting the DC sources sequentially to the AC side via the four semiconductor power devices. [12]

Each level of the full bridge converter consists of four switches. Using the top level as the example, by turning ON S1 and S4, yields $V_1 = +V_{dc}$. By turning ON S2 and S3, yields $V_1 = -V_{dc}$. Turning OFF all switches yields $V_{dc} = 0$. Similarly, the AC output voltage at each level

can be obtained in the same manner.

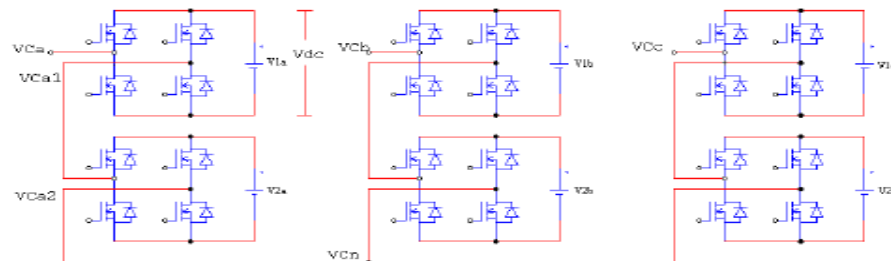

Fig 4 Basic Structure of the Cascaded Inverter

The simulation work mainly focuses on

The comparison between different levels of three phase Cascaded Multilevel Inverters based on the PI controller.

The comparison is done on the basis of output Total Harmonic Distortion, fundamental and harmonic of the rms voltage and input DC utilization.

Simulation of single phase CMLI inverter is not presented since the proposed work mainly focuses on the three phase inverter for high power industrial drive applications. The most important aspect which sets the cascaded H Bridge apart from other multilevel inverters is the capability of utilizing different DC voltages on the individual H bridge cells. In two level PWM, the switching frequency is always equal to the carrier frequency for modulation indices less than unity. In the multilevel PWM, the switching frequency can be less than or greater than the carrier frequency and is a function of the displacement angle between the carrier set and the modulation waveform.

The general structure of the multilevel converter is to synthesize a near sinusoidal voltage from several levels of DC voltages. As more steps are added to the waveform, the harmonic distortion of the output wave decrease, approaching zero as the number of levels increases.

IV. SIMULATION DIAGRAM OF THE PROPOSED SYSTEM

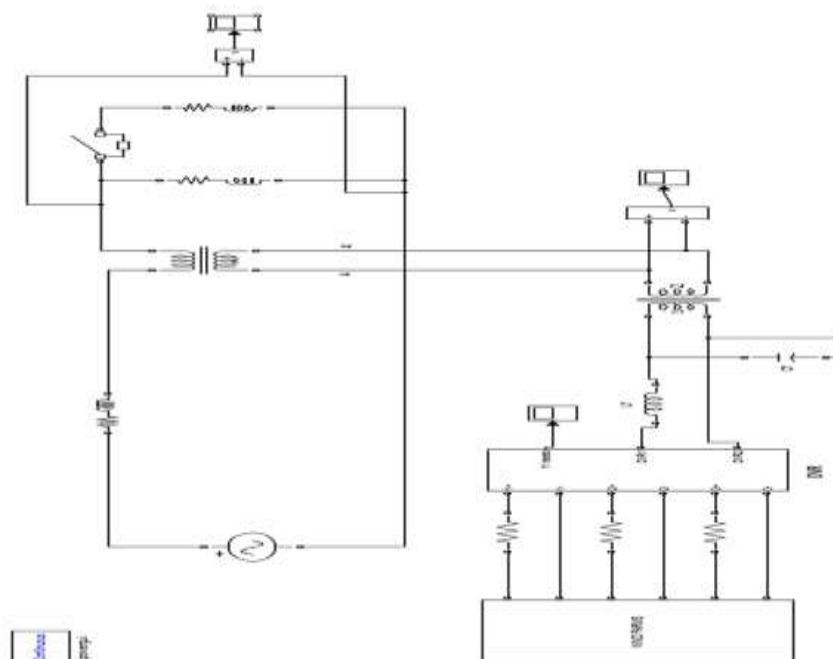

Fig 6 Simulation Diagram of an eleven level Inverter with DVR

V SIMULATED RESULTS

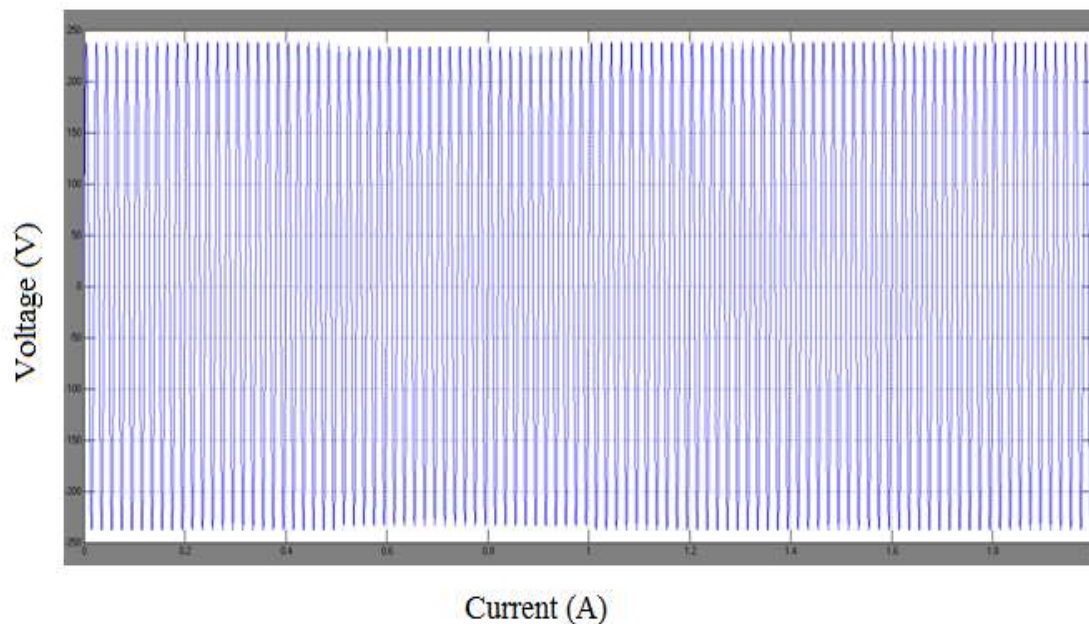

Fig 8 Output Waveform with DVR

VI CONCLUSION

This multilevel inverter system was designed with a perspective to make a distribution system with minimum harmonics and vital for the improvement in power factor. Thus this application falls under a suitable integration of STATCOM with dual storage of power in grid. In future complete eradication of harmonics is vital for improvement in distribution system.

REFERENCES

- [1] S. Dineshkumar and N. Senthilnathan, "Three Phase Shunt Active Filter Interfacing Renewable Energy Source with Power Grid," *Communication Systems and Network Technologies (CSNT), 2014 Fourth International Conference on*, Bhopal, 2014, pp. 1026-1031
- [2] AWEA U.S. Wind Industry Annual Market Report Year Ending 2010, AWEA, Washington, DC, USA, 2011.
- [3] S. A. Rahman, R. K. Varma, and W. H. Litzemberger, "Bibliography of FACTS applications for grid integration of wind and PV solar power systems: 1995–2010 IEEE working group report," in *Proc. IEEE Power Energy Soc. General Meeting*, Jul. 2011, pp. 1–17.
- [4] A. Beekmann, J. Marques, E. Quitmann, and S. Wachtel, "Wind energy converters with FACTS capabilities for optimized integration of wind power into transmission and distribution systems," in *Proc. CIGRE/IEEE PES Joint Symp. Integr. Wide, Scale Renew. Resource Power Del. Syst.*, Jul. 2009, pp. 1–9.
- [5] J. Rodriguez, J. S. Lai, and F. Z. Peng, "Multilevel inverters: Survey of topologies, controls, and applications," *IEEE Trans. Ind. Appl.*, vol. 49no. 4, pp. 724–738, Aug. 2002.
- [6] L. M. Tolbert and F. Z. Peng, "Multilevel converters as a utility interface for renewable energy systems," in *Proc. IEEE Power Eng. Soc. Summer Meeting*, vol. 2. Jul. 2000, pp. 1271–1274.
- [7] S. Kouro, M. Malinowski, K. Gopakumar, J. Pou, L. G. Franquelo, B. Wu, et al., "Recent advances and industrial applications of multilevel converters," *IEEE Trans. Ind. Electron.*, vol. 57, no. 8, pp. 2553–2580, Aug. 2010.
- [8] C. Tareila, P. Sotoodeh, and R. D. Miller, "Design and control of a single-phase D-STATCOM inverter for wind application," in *Proc. PEMWA*, Jul. 2012, pp. 1–5.
- [9] B. Gultekin and M. Ermis, "Cascaded multilevel converter-based transmission STATCOM: System design methodology and development of a 12 kV \pm 12 MVAR power stage," *IEEE Trans. Power Electron.*, vol. 28, no. 11, pp. 4930–4950, Nov. 2013.



- [10] K. Sano and M. Takasaki, "A transformer less D-STATCOM based on a multivoltage cascade converter requiring no DC sources," IEEE Trans. Power Electron., vol. 27, no. 6, pp. 2783–2795, Jun. 2012.
- [11] X. Liang, Y. Xu, X. Chen, and C. Guo, "The simulation research of STATCOM based on cascaded multi-level converter," in Proc. 4th Int. Conf. Electr. Util. DRPT, Jul. 2011, pp. 494–498.
- [12] M. Davies, M. Dommaschk, J. Dorn, J. Lang, D. Retzmann, and D. Soerangr, HVDC PLUS Basic and Principle of Operation. Erlangen, Germany: Siemens AG Energy Sector, 2009.

Author' biography with Photo



GN. Sachinamreiss, Assistant professor in department of Electrical & Electronics engineering, M. Kumarasamy College of Engineering, Karur. The author completed his under graduate and post graduate course in PGP college of engineering and technology, Namakkal. Also presented paper in various platform in regard to power electronics



S. Dineshkumar, Assistant Professor in department of Electrical and Electronics Engineering, M. Kumarasamy College of Engineering, Karur. The author completed his under graduate and post graduate course in Kongu Engineering College, Erode. Also the author presented the papers in journal and national and international conferences in Electrical Drives and Renewable Energy.