



## A Novel Componentless Power Quality Improvement Technique for Renewable Energy Sources

R.Anandaraj<sup>1</sup>, A.Albert Martin Ruban<sup>2</sup>, Dr.N.Kannan<sup>3</sup>

1 Research Scholar, Manonmaniam Sundaranar University and Associate Professor, E.G.S Pillay Engineering College, Nagappattinam.

2 Research Scholar, Manonmaniam Sundaranar University and Associate Professor, Kings College of Engineering, Pudukkottai.

3 Principal, Jayaram Engineering College, Thuraiyur.

### ABSTRACT

The main aim in power distribution system is to provide uninterrupted flow of energy at smooth sinusoidal voltage at the contracted magnitude level and frequency. However in wind power generation have numerous non linear loads, which significantly affect the quality of the power supplies. As the power of the non linear loads, the purity of the waveform of supplies is lost. In this proposed work, multiple port choppers is used to handle power quality issues such as voltage sags, harmonic distortion, in addition to normal wind turbine supplying to the customer during normal operation. The wind generation with micro turbine provides the flexibility of operation to the customer. The micro turbine based DVR can recover voltage sags in the supply voltage during abnormal load. On the other hand, it will operate as a separate DG when the wind power supply fails to supply the desired power.

### Indexing terms/Keywords

Micro turbine, Dynamic Voltage Restorer (DVR), Power electronics interface, Voltage Injection and Filter.

### Academic Discipline And Sub-Disciplines

Engineering; Electrical

### SUBJECT CLASSIFICATION

Renewable Energy Sources

### 1. INTRODUCTION

To maintain the quality of power, we use the Micro turbine and Dynamic Voltage Restorer (DVR). Micro turbine based DVR system is comprised of gas turbine with low and high power DC-DC converter, PWM voltage source inverter, series injection transformer and semiconductor switches.

Micro turbine is well suitable for a different distributed generating application. Because the Micro turbine is flexible in connection method, can be stacked in parallel to serve larger load. In location where power from the local grid is unavailable or extremely expensive to install, or the customer is far from the distribution system the Micro turbine can be a competitive option. The Micro turbine system can generate power in the range of 25 kW to 500 kW and can be operated in stand alone, mobile, remote or interconnected with the utility applications. This generation system can be used for a wide range of applications.

### 2. MICRO TURBINE

Micro turbines are very small gas combustion turbines, featuring a single shaft structure with no gearboxes and rotating at very high speed, typically between 50,000 and 120,000 rpm/min; as a consequence these machines are always equipped with permanent magnet synchronous generators to produce electricity.

This is the basic model which has been used by several researchers to model the micro turbine. The Matlab/Simulink implementation of the Micro turbine model including all its control systems is shown in figure 1.

The model consists of temperature control, fuel control, turbine dynamics, and speed governor and acceleration control blocks. The droop governor is a straight proportional speed controller in which the output is proportional to the speed error. Speed control is usually modeled by using a lead lag transfer function or by a PID controller. The temperature control is the common method of limiting gas turbine output at a re-determined firing temperature, independent of variation in ambient temperature or fuel characteristics.

The micro turbines are much smaller in physical dimension than a conventional gas turbine. The length of each component of relatively short and the gas moves relatively fast speed inside the micro turbine compartment hence each compartment of micro turbine has a small thermodynamic time constant. Thus any change in the input of fuel or the air flow of a micro-turbine affects its output mechanical power in short period of time. Therefore, thermodynamics of micro turbine should be considered in the analysis of a dynamic performance of the MTG, and input mechanical power to the generator cannot be considered as constant value during electro-mechanical dynamics of generator.



Generally micro turbines have the three main parts. There are single shaft turbines with its control system, high speed permanent magnet generator, and power electronics interfacing (rectifier and voltage source inverter).

## 2.1 TURBINE

There are essentially two types of turbine design; one is a high speed single shaft design with the compressor and turbine mounted on the same shaft as the permanent magnet synchronous generator. Another is split type shaft design that uses a power turbine rotating at 3600 rpm.

## 2.2 PERMANENT MAGNET SYNCHRONOUS GENERATOR (PMSG)

The important applications of permanent magnet synchronous machine are in the wind and Micro turbine based distributed generation systems. One of the major advantages of PMSG is the possibility of super high speed operation leading to a very small unit as the size of the machine decreases almost in directly proportion to the increase in speed. Super high speed PMSG is an important component of single shaft MTG system.

## 2.3 POWER ELECTRONIC INTERFACE

A Cycloconverter can be used to interface the MTG system to the grid. These converters directly convert AC voltages at one frequency to AC voltages at another frequency with variable magnitude. For this reason, they are also called frequency changers.

## 3. DYNAMIC VOLTAGE RESTORER (DVR)

The problems of voltage sags and swells and its severe impact on sensitive loads are well known. To solve this problem, custom power devices are used. One of those devices is the Dynamic Voltage Restorer (DVR), which is most efficient and effective modern custom power devices used in power distribution networks. Its appeal includes lower cost, smaller size and its fast dynamic response to the distribution. A Dynamic Voltage Restorer (DVR) is a recently proposed series connected solid state devices that that inject voltage into the system in order to regulate the load side voltage. The DVR was first installed in 1996. Its normally installed in a distribution system between the supply and the critical load feeder. Its primary function is to rapidly boost up the load side voltage in the event of a distribution in order to avoid any power distribution to that load.

The general configuration of the DVR consists of an injection / booster transformer, a Harmonic filter, a Voltage Source Converter (VSC), DC charging circuit and a Control and Protection system. This simulation diagram of DVR is as shown in Figure 2.

### 3.1 INJECTION / BOOSTER TRANSFORMER

The injection / booster transformer is a specially designed transformer that attempts to limit the coupling of noise and transient energy from the primary side to the secondary side.

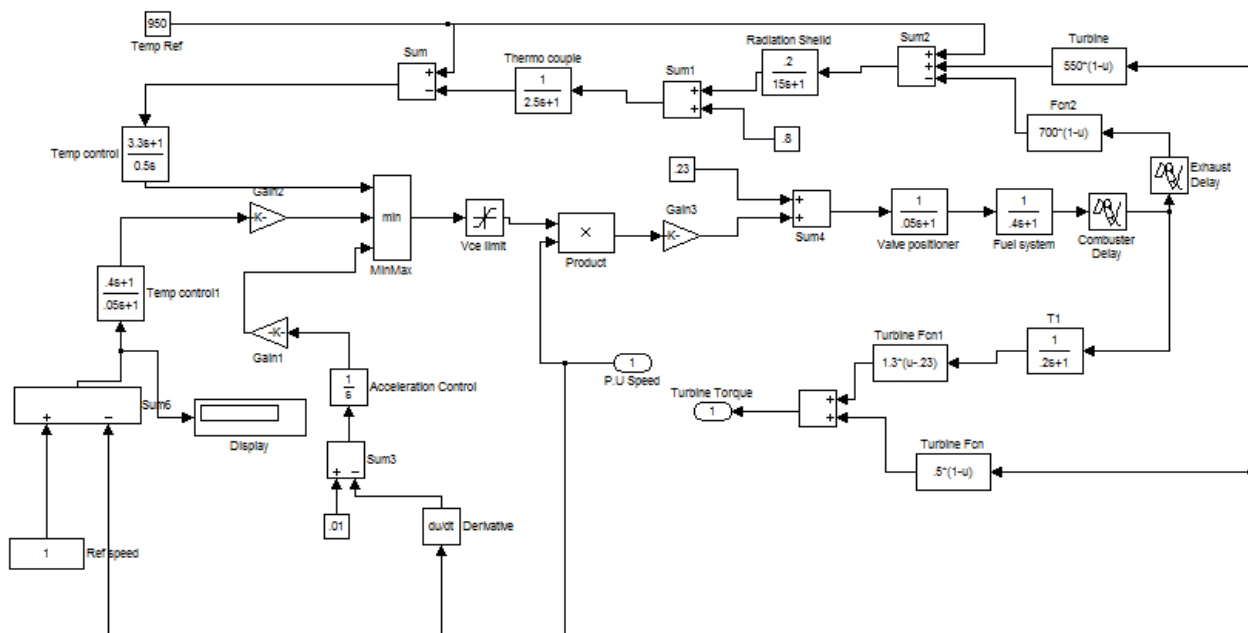

Fig1: Simulation diagram of Micro turbine

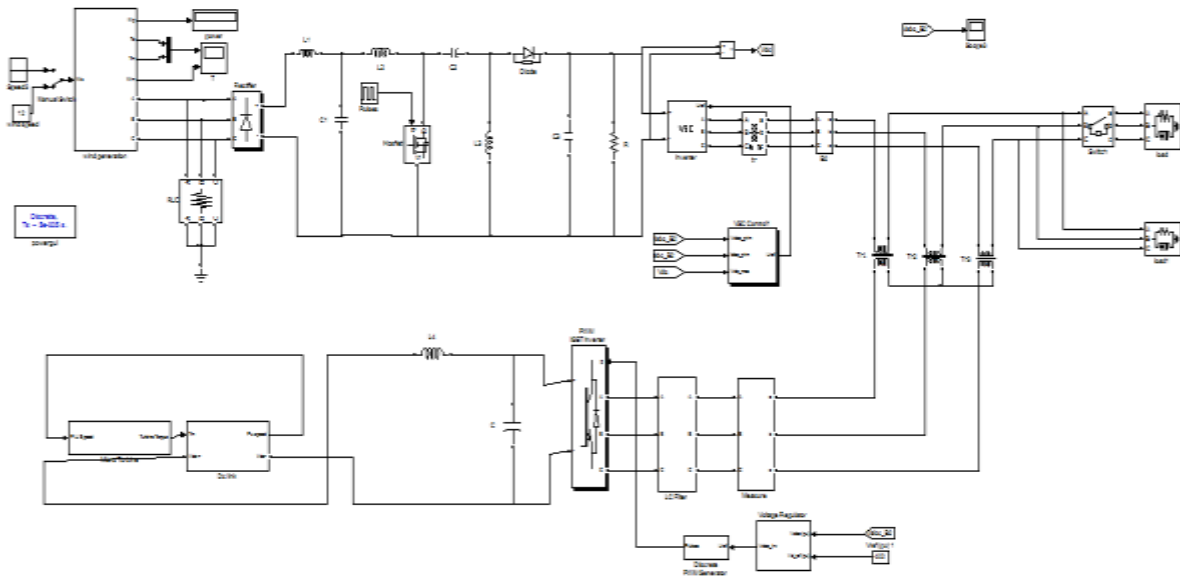

Fig 2: Simulation diagram of DVR

Its main tasks are: connects the DVR to the distribution network via the HV-windings and transforms and couples the injected compensating voltages generated by the voltage source converters to the incoming supply voltage. In addition, the injection or booster transformer serves the purpose of isolating the load.

### 3.2 HARMONIC FILTER

The main task of harmonic filter is to keep the harmonic voltage content generated by the voltage source converters to the permissible level. It has a small rating approximately 2% of the load MVA connected to delta-connected tertiary winding of the injection transformer.

### 3.3 VOLTAGE SOURCE CONVERTER

A VSC is a power electronic system consists of a storage device and switching devices, which can generate a sinusoidal voltage at any required frequency, magnitude, and phase angle. In the DVR application, the VSC is used to temporarily replace the supply voltage or to generate the part of the supply voltage.

### 3.4 SWITCHING DEVICES

There are four main types of switching devices: Metal Oxide Semiconductor Field Effect Transistors (MOSFET), Gate Turn-Off Thyristors (GTO), Insulated Gate Bipolar Transistors (IGBT), and Integrated Gate Commutated Thyristors (IGCT). Each type has its own benefits and drawbacks. The IGCT is a recent compact device with enhanced performance and reliability that allows building VSC with very large power ratings. Because of the highly sophisticated converter design with IGCTs, the DVR can compensate dips which are beyond the capability of the past DVRs using conventional devices.

### 3.5 STORAGE DEVICES

The purpose is to supply the necessary energy to the VSC via a dc link for the generation of injected voltages. The different kinds of energy storage devices are superconductive magnetic energy storage (SMES), batteries, and capacitance. Batteries are the common choice and can be highly effective if a high voltage battery configuration is used. An interesting alternative to batteries is the use of ultra capacitors, which have a wider voltage range than batteries and can be directly paralleled across the input bus.

### 3.6 DC CHARGING CIRCUIT

The dc charging circuit has two main tasks. The first task is to charge the energy source after a sag compensation event. The second task is to maintain dc link voltage at the nominal dc link voltage. Different topologies are used to charge the dc-link such as an external power supply or by connecting the dc side of the DVR to the controlled or uncontrolled rectifier to maintain the dc voltage. The other side of the rectifier can be from a main power line or from an auxiliary feeder.

### 3.7 CONTROL AND PROTECTION

The control mechanism of the general configuration typically consists of hardware with programmable logic. Although To maximize dynamic performance, direct feed forward type control architecture should be applied in the control concept of the DVR. With this concept a fast response time (Approximately 1ms) can be achieved to compensate voltage sags. All protective functions of the DVR should be implemented in the software. Depending on the particular fault condition, the fast control and protection may switch the DVR into bypass if it becomes inoperable, thus securing an uninterrupted energy flow to the customer's plant.

### 3.8 OPERATING PRINCIPLE OF DVR

The basic function of the DVR is to inject a dynamically controlled voltage generated by a forced commutated converter in series to the bus voltage by means of a booster transformer. This means that any differential voltages caused by transient disturbances in the ac feeder will be compensated by an equivalent voltage generated by the converter and injected on the medium voltage level through the booster transformer.

The DVR has two modes of operation which are: standby mode and boost mode. In standby mode ( $VDVR=0$ ), the booster transformer's low voltage winding is shorted through the converter. No switching of semiconductors occurs in this mode of operation, because the individual converter legs are triggered such as to establish a short-circuit path for the transformer connection. The DVR will be most of the time in this mode. In boost mode ( $VDVR>0$ ), the DVR is injecting a compensation voltage through the booster transformer due to a detection of a supply voltage disturbance.

### 3.9 DVR VOLTAGE INJECTION

The possibility of compensating voltage sag can be limited by a number of factors including finite DVR power rating, different load conditions and different types of voltage sag. Some loads are very sensitive to phase angle jump and others are tolerant to it. Therefore, the control strategy depends on the type of load characteristics. There are three different methods for DVR voltage injection are Pre-Dip Compensation (PDC), In-Phase Compensation (IPC), In Phase Advance Compensation (IPAC).

In order to show the performance of the DVR in voltage sags and swells mitigation, a simple distribution network is simulated using MATLAB in figure 1. Voltage sags and swells are simulated by temporary connection of different impedances at the supply side bus. A DVR is connected to the system through a series transformer with a capability to insert a maximum voltage of 50% of the phase to ground system voltage. Apart from this, a series filter is also used to remove any high frequency components of power.

## 4. MODELLING

The proposed method is validated by simulation results of MATLAB/Simulink. The system parameters are given in the Appendix. DVR with hysteresis voltage control is applied to compensate load voltage. Here we consider two different cases.

In figure 1, the unbalanced voltage sag is simulated. To demonstrate the performance of the proposed method we assumed voltage swell condition in figure 2. In order to demonstrate the performance of the DVR using unipolar and bipolar switching technique to control, a Simulink diagram proposed as shown in Figure.2.

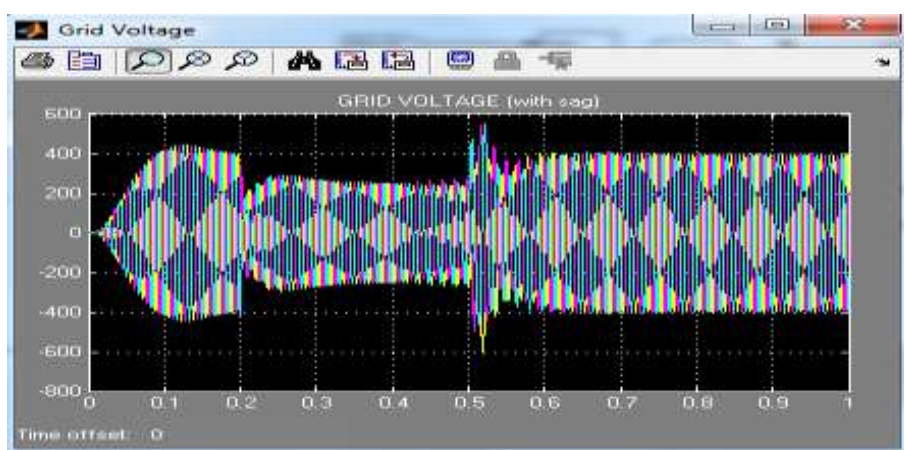

**Fig 3: Output Voltage with SAG**  
(Without DVR)

In this case, we assume that there is a 30% three-phase voltage sag with  $+30^\circ$  phase jump in phase-a in supply voltage that is initiated at 0.1s and it is kept until 1.8 sec. Figure 3 shows the result of voltage sag compensation considering hysteresis Voltage control based on bipolar switching for  $HB1=0.005$ . The outcome of voltage sag compensation considering hysteresis voltage control based on unipolar switching for  $HB1=0.005$  and  $HB2=0.007$  is demonstrated in Figure.3

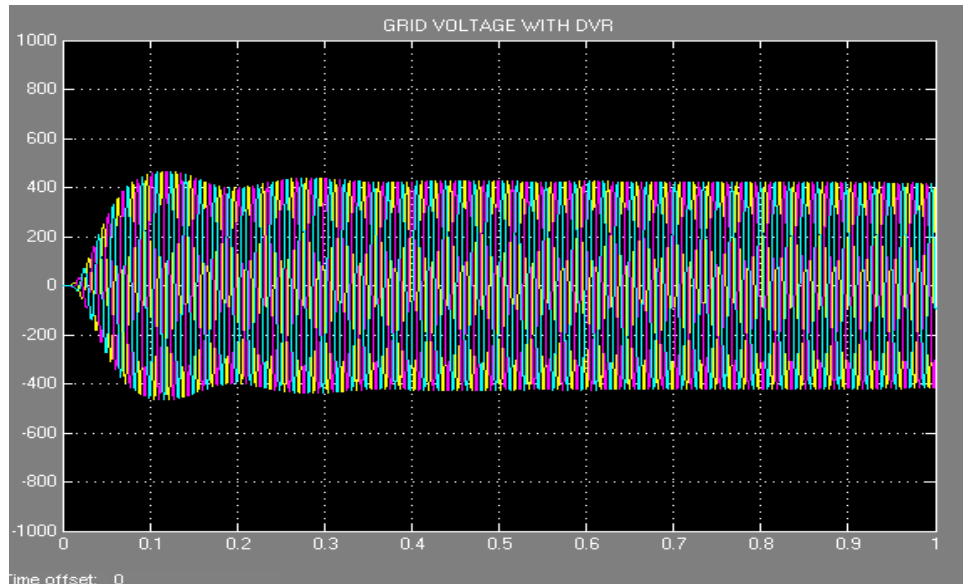

**Fig 4: Output Voltage With DVR**

Figure 4 show the serial injected voltage components. Moreover, the compensated load voltage is shown Figure 4. As it can be seen from the results, the DVR is able to produce the required voltage components for different phases and help to maintain a balanced and constant load voltage at the nominal value. Simulation results proved the capability of the proposed DVR in mitigating the voltage sag in a grid system. Magnitude of voltage with appropriate phase angle using the micro turbine based dynamic voltage restorer. This experiment is verified with the software environment of Matlab2010.a.This results are verified.

## 5. CONCLUSION

The proposed work consists of a wind turbine with fast acting micro turbine as a dynamic voltage restorer (DVR).The DVR can have the capability of mitigating the voltage sag produced during abnormal load condition in the grid. This voltage sag in-turn produces not only a reduced voltage but also a waveform of distortion due to the abnormal load this both issues are simulated during the time of 0.2second to 0.5second. This problem is effectively reduced by injecting suitable magnitude of voltage with appropriate phase angle using the micro turbine based dynamic voltage restorer. This experiment is verified with the software environment of Matlab2010.a.This results are verified.

## References:

1. D. N. Gaonkar and R. N. Patel, "Modelling and simulation of micro turbine based distributed generation system," in IEEE Power India conference, New-Delhi, India, April 2006.
2. D. N. Gaonkar and Sanjeev Nayak, "Modeling and Performance Analysis of Microturbine Based Distributed Generation System a review" in IEEE, 2011.
3. Gang Li, Gengyin Li, Wei Yue, Ming Zhou, and K L Lo, "Modeling and Simulation of a Microturbine Generation System Based on PSCAD/EMTDC" in IEEE, 2010.
4. H. Ezoji, A. Sheikholeslami, M. Tabasi, M.M. Saeednia, "Simulation of Dynamic Voltage Restorer Using Hysteresis Voltage Control" in European Journal of Scientific Research, Vol.27- 2009.
5. Wenyong Guo, Liye Xiao, Shaotao Dai, and Liangzhen Lin, "Control Strategy of a 0.5 MVA/1 MJ SMES Based Dynamic Voltage Restorer" in IEEE, June 2010.
6. Chellali Benachaba, Brahim ferdi, "Voltage Quality Improvement Using DVR" in Electrical Power Quality and Utilisation, Journal Vol. XIV, 2008.