



Step by Step Design Analysis and Calculations of an African Breadfruit Dehulling Machine

¹Ozigbo Emmanuel S. and ²Murphy Kayode M.

¹University of Ibadan, Ibadan

Email: emmanuel.ozigbosunday@gmail.com

²International Institute of Tropical Agriculture, Ibadan

Email: kaymurp@yahoo.co.uk

ABSTRACT

African breadfruit seeds dehulling is a lucrative business in Nigeria. There is a high demand of the seeds in Southeastern of the Country. A little quantity of it is highly priced in the market. Despite the high demand of the breadfruit seeds for both nutritional and medicinal value, the rural processors usually dodge the production process. This is as a result of hard labour, time wasted and rigorous processes as associated with the manual method of dehulling the seeds – which are usually over 900 seeds in a single fruit, spongy pulp. The seeds have two coats, the outer coat is usually harder and thicker than the inner coat which make dehulling operation more tedious. The dehulling takes about 70% operation of the African breadfruit processing. Therefore, this paper reviewed the types of materials that can be used for fabrication a dehuller; designs considerations; design analysis and calculations of an African breadfruit seeds dehuller so as to provide a working document for designers and fabricators who may want to go into the production of African breadfruit seeds dehullers.

Keywords: Dehulling, Design; African breadfruit seed; Machine; Production.



Council for Innovative Research

Peer Review Research Publishing System

Journal: JOURNAL OF ADVANCES IN AGRICULTURE

Vol. 5, No. 2

www.cirjaa.com, jaeditor@gmail.com

editor@cirjaa.com



INTRODUCTION

Breadfruit is a great economic tree. From its leaves, fruits, stem to other parts of the tree such as the root, experts have found *T. africana* Decne and its other variants present in other parts of the world immensely useful in the treatment of many chronic ailments such as diabetes, acute Ischemia and hypertension [1]. According to [2], African breadfruit (*Treculia africana*) tree is a multipurpose and medicinal plant species which belongs to the family Moraceae and order of Urticales.

The seeds are used as flavouring in alcoholic drinks and edible oil can be processed from the seeds [3]; [4]. [5] reported that the seeds of African breadfruits have an excellent polyvalent dietetic value whose biological value exceeds that of soybeans. A mature seed consists of two layers; an outer seed coat and an inner edible endosperm. The husks are coated with a thin viscous highly hydrated layer or mesocarp similar to the coffee bean mucilage. He further explained that African breadfruit is brown in colour but the colour changes black due to oxidation after fermentation period of 6 – 12 days. The fermentation is normally done to degrade the fruit pulp and seed mucilage so as to facilitate the extraction of the seeds [6]. All these processes are considered as the primary processing of the African breadfruit while the process starts with the dehulling operation.

Despite the high demand of the breadfruit seeds for both nutritional and medicinal value in the southeastern part of country, most rural dwellers prefer hawking other local fruits like cashew nut, orange, tiger nut, walnut, better kola to African breadfruit as business. This is simply because there is a lengthy and tedious process involve in manual extraction of the seeds from the fruit. According to [6], prior to cleaning of the seed is a fermentation process and demucilagination which impacts a characteristic offensive odour to the seeds if not properly washed. Hence, the seeds have to be washed out thoroughly from the fruit which consumes a lot of time and large volume of water. Therefore, a good source of water (bore-hole or river or stream) is required. A fruit, spongy pulp contains about 900 seeds (18 inches in diameter) depending on the size. This is a major problem during the secondary processing, dehulling of the seeds. Traditionally, this is usually done manually with hands which is tiresome and takes over 70% of the total time of the operation. This process scares most people away from the entire processing of African breadfruit. Another major factor that limits African breadfruit availability is its poor storability as the fruits undergo rapid physiological deterioration after harvesting. All these contribute to reasons why a little quantity of processed African breadfruit seeds is highly priced in the market.

A simple, cheap, non gender-selective, high delivery capacity, easy to operate and high efficient Africana breadfruit seed dehulling machine will go a long way in breadfruit processing companies to remove the drudgery and time wastage associated with hand/manual method of dehulling of the seed, expand the breadfruit production capacity, increase economic returns to the breadfruit processors, ensure sustainability; guarantee continual production throughout season, solve the problem of scarcity of the breadfruit seeds in the southeastern part of the country.

Various works have been carried by some researchers on African breadfruit seeds dehulling machine such as [7]; [8]. The aim of this study is to review the step by step method of designing and fabricating a successful African breadfruit seeds dehuller.

MATERIALS AND METHODS

Materials

There are two major types of materials that are economical in the fabrication of a local breadfruit dehulling machine which are readily available, cheap, quite common and easy to adjust. These are wooden and metallic materials. Both soft and hard part of Obeche and Mahagony are good wooden materials for construction of a dehulling system. The metallic dehuller may consist of material components such as mild steel angle iron; mild steel sheet, mild steel flat bar; bolts and nuts (10,12,13,14,15) & washers; air & fuel hoses; fan belt; pillo bearing; ball bearing; mild steel shaft; ½ inch Plywood, galvanized pipe, etc. The machine can be made of solely metallic or wooden components or combination of both. It can be designed to be powered by an electric supply or driven by a gasoline engine as a prime mover or primary source of power.

Design Considerations

A good knowledge of the engineering properties (physical, rheological, gravimetric, frictional, aerodynamic and mechanical) of any biomaterial under study is paramount in the development of any postharvest equipment either for harvesting, processing, handling, conveying, cleaning, delivering, dehulling, or storage of the biomaterial.

The physical and mechanical properties of the African breadfruit seeds (*Treculia africana* Decne) such as cracking force, strength, hardness of the seeds; geometric properties of the African breadfruit seed (length, width, thickness, geometric mean diameter, and sphericity), gravimetric properties (including true density, bulk density and porosity) and frictional properties (angle of repose and static coefficient of friction) of the seed in order to acquire an acceptable efficiency should be considered.

The other important parameters to be considered for a successful design and the fabrication of any dehulling machine are as follows: choice of materials (material selection), strength of the materials, availability of the materials, affordability of the materials, choice of power drive of the dehuller, capital, selection of the aspirator type, operating and maintenance cost of the machine to justify its preference over others dehulling means.



Design Calculations and Analysis

1. The Design of Hopper

In designing a hopper, it is recommended that the angle of inclination of the hopper walls be 10° higher than the natural angle of repose of the stored material (breadfruit seeds) [9], this is to avoid tunneling and arching during the discharge of the breadfruit seeds.

The angle of repose of the breadfruit obtained experimentally by [7] is 28.6° . Therefore, angle of inclination of 39° will be used in designing the hopper. The shape of the hopper is like that of a frustum of a pyramid. Using the equation below by [10], the volume of the hopper can be estimated as:

$$V = \frac{h}{3} [A_1 + A_2 + \sqrt{(A_1 + A_2)}] \quad (1)$$

$$\text{Where,} \quad A = l \times b \quad (2)$$

V = Volume of hopper (m^3)

A_1 = Area of Top (m^2);

A_2 = Area of Base (m^2)

h = Height of the Hopper (m)

L = Length (m)

B = Base (m)

For example, where, $A_1 = 0.2 \text{ m}$; $A_2 = 0.058 \text{ m}$; $B = 0.2 \text{ m}$; $h = 0.0235 \text{ m}$, the volume of the hopper can be estimated as follows;

$$A_1 = L \times B = (0.2 \text{ m} \times 0.2 \text{ m}) = 0.04 \text{ m}^2$$

$$A_2 = L \times B = 0.058 \text{ m} \times 0.058 \text{ m} = 0.003364 \text{ m}^2$$

$$h = 0.0235 \text{ m}$$

$$V = \frac{0.0235}{3} [0.04 + 0.003364 + \sqrt{(0.04 + 0.003364)}]$$

$$V = 0.007833[0.04336 + 0.2082]$$

$$V = 0.007833 \times 0.2516$$

$$V = 0.00197 \text{ m}^3 = 2.0 \text{ liters}$$

Although the volume of the hopper is quite small compared to its purpose for a commercial dehuller but this is okay for a prototype.

2. The Design of the Frame

Determination of Shear Forces Reaction at the Bearings and Bending Moment:

$$W = \frac{mg}{l} \quad (3)$$

$$\text{Where,} \quad m = w_1 + w_2 + w_3 + w_4 \quad (4)$$

Considering the following design specifications as examples, the shear forces can be determined as follows;

$$m = \text{total mass on the shaft} = 6.00 \text{ kg}$$

$$l = \text{length of the shaft} = 0.58 \text{ m}$$

$$g = \text{gravitational constant} = 9.81 \text{ m/s}^2$$

$$w_1 = \text{mass of the shaft alone} = 2.00 \text{ kg}$$

$$w_2 = \text{mass of the dehulling drum} = 2.80 \text{ kg}$$

$$w_3 = \text{mass of the wooden worms} = 0.45 \text{ kg}$$

$$w_4 = \text{mass of the pulleys} = 0.75 \text{ kg}$$

$$W = \frac{6.00 \times 9.81}{0.58} = 101.48 \text{ N/m}$$

Weight per unit length of the shaft, $W = 101.48 \text{ N/m}$

Therefore, the reactions at the support for a point load can be estimated as follows;

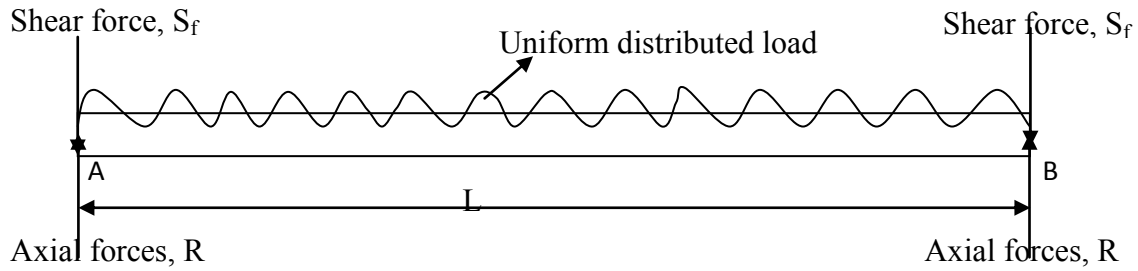

Fig. 1: Shear Force Diagram for a Uniform Distributed Load

$$R = R_A = R_B = \frac{wl}{2} \tag{5}$$

$$R = \frac{101.48 \text{ N/m} \times 0.58 \text{ m}}{2} = 29.43 \text{ N}$$

$$\therefore R_A = 29.43 \text{ N}; R_B = 29.43 \text{ N}$$

For the bending moments;

$$B_{MA} = B_{MB} = 0$$

Where;

B_{MA} = bending moment of the shaft about the support reaction A (Nm),

B_{MB} = bending moment of the shaft about the support reaction B (Nm)

[11] gave the bending moment for a point reaction uniformly distributed across the shaft length as,

$$B_{MX} = \frac{Rl}{8} \tag{6}$$

B_{MX} = point where the bending moment is at maximum (Nm),

l = length of the shaft (m) = 0.58 m.

Therefore, the bending moment at point C is;

$$B_{MC} = \frac{R \times l}{8} \tag{7}$$

Where B_{MC} is the bending moment at the center of the shaft

$$B_{MC} = \frac{29.43 \text{ N} \times 0.58 \text{ m}}{8} = 2.13 \text{ Nm}$$

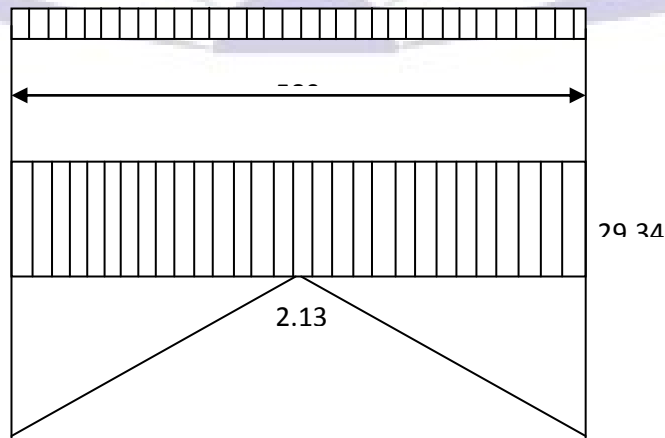

Fig. 2: Bending Moment Diagram



3. The Design of the Dehulling Chamber

(I) Shaft Selection

According to [12], the diameter of the shaft to be used can be determined using the equation below:

$$d = \left[\frac{16}{\pi S} \sqrt{(K_b M_b)^2 + (K_t M_t)^2} \right]^{\frac{1}{3}} \quad (8)$$

For the following materials specifications below, the diameter of the shaft is given as;

$$d = 15 \text{ mm}$$

M_b = Maximum bending moment on shaft (Nm) = 17.19 N/m

M_t = Maximum torsional moment on shaft (Nm) $\approx 2.35 \text{ Nm}$

K_b = Dimensional combined and fatigue factor applied to bending moment = 1.5

K_t = Dimensional combined and fatigue factor applied to torsional moment = 1.0

S_x = Allowable shear stress for steel $40 \times 10^6 \text{ N/m}^2$ (ASME code)

$$\begin{aligned} d &= \left[\frac{16}{3.142 \times 40 \times 10^6} \sqrt{(1.5 \times 17.19)^2 + (1 \times 2.35)^2} \right]^{\frac{1}{3}} \\ &= [1.27307447 \times 10^{-7} \sqrt{664.87 + 5.52}]^{\frac{1}{3}} \\ &= [1.27307447 \times 10^{-7} \sqrt{670.39}]^{\frac{1}{3}} \\ &= [1.27307447 \times 10^{-7} \times 25.89]^{\frac{1}{3}} \\ &= (3.2962 \times 10^{-6})^{\frac{1}{3}} \\ &= 0.0149 \approx 0.0150 \text{ m} \end{aligned}$$

$$d = 15 \text{ mm} + \text{factor of safety}$$

Using 20% as the factor of safety for the diameter of a shaft is reported in [13], therefore, shaft to be used here is 19 mm.

(II) Determination of Volume of the Dehulling Chamber

According to [14], it was reported that the volume of the dehulling chamber is expressed as;

$$V_{dc} = \pi r_d^2 l \quad (9)$$

Where the specifications are given as below, the Volume of the dehulling chamber can be computed.

r_d = radius of dehulling chamber (m) = 0.055 m,

l = length of dehulling chamber (m) = 0.34 m

$$\begin{aligned} V_{dc} &= \pi \times 0.055^2 \times 0.34 \\ V_{dc} &= 3.142 \times 0.055^2 \times 0.34 \\ V_{dc} &= 0.00323 \text{ m}^3 \end{aligned}$$

(III) Volume of Shaft in Dehulling Chamber (V_s)

[14] stated that the volume of roller (drum) in a dehulling chamber is expressed as;

$$V_s = \pi r_s^2 l_s \quad (10)$$

Where;

r_s = radius of shaft (m) = 0.04 m

l_s = length of shaft (m) = 0.58 m

$$V_s = \pi \times 0.04^2 \times 0.58$$

$$V_s = 3.142 \times 0.04^2 \times 0.58$$



$$= 0.0029 \text{ m}^3$$

(IV) Volume of Seed in Dehulling Chamber (V_{cs})

The volume of the seed (V_{cs}) in the dehulling chamber as explained by [14] is obtained by subtracting the volume of shaft (V_s) in the dehulling chamber from the volume of the dehulling chamber (V_{dc}).

$$V_{cs} = V_{dc} - V_s \quad (11)$$

$$= 0.00323 \text{ m}^3 - 0.0029 \text{ m}^3$$

$$V_{cs} = 0.00033 \text{ m}^3 \approx 3.3 \text{ litres}$$

4. The Design of the Blower

This section determines the fluid flow rate and discharge velocity of the blower. The figure 4 below shows the velocity triangle of the air flow leaving the impeller. Since there are no inlet guide vanes, the entering flow has no tangential component of motion [15]. The entering flow is in radial direction, and which is the radial component of the absolute velocity, therefore the inlet velocity, V_1 . It is assumed that the flow is completely guided by the blades and that the flow angles coincide with the blade angles. Following the below design specifications, the blower discharge capacity can be estimated;

Vane Angle, $\beta = 67^\circ$

Volute radius, $r = 50 \text{ mm} \approx 0.05 \text{ m}$;

Vane Width at the Suction Eye, $b = 80 \text{ mm} \approx 0.08 \text{ m}$;

Rotational speed of the engine, $N = 2400 \text{ rpm}$

Area of the discharge end of the blower, $A = 100 \times 100 \text{ mm} = 10,000 \text{ mm}^2 \approx 0.01 \text{ m}^2$

The linear Speed at the inlet is;

$$U = r \times \omega \quad (12)$$

$$U = r \times \omega = r \times \frac{2\pi N}{60} \quad (13)$$

$$= 0.05 \times \frac{2\pi \times 2400}{60} = 12.57 \text{ m/s}$$

$$V_1 = U \tan \beta \quad (14)$$

$$= U \tan \beta = 12.57 \tan 67^\circ = 29.61 \text{ m/s}$$

The expected flow rate is

$$Q = 2 \pi r V_1 \quad (15)$$

$$= 2 \pi r V_1 = 2 \times 3.142 \times 0.05 \times 0.08 \times 29.61$$

$$= 0.7447 \text{ m}^3/\text{s}$$

Applying continuity concept at the blower discharge

$$V_2 = \frac{Q}{A} \quad (16)$$

$$= \frac{0.744}{0.01} = \frac{74.4 \text{ m}}{\text{s}} \quad \text{this why the output of the blower is very efficient}$$

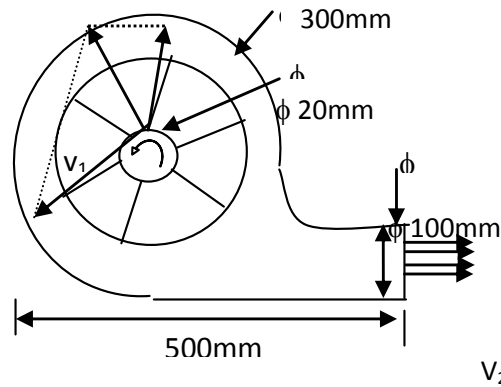

Fig. 4: Impeller cross-section in the blower showing the velocity diagram

5. Estimation of Power Requirement of the Dehuller

The power requirement to drive an African breadfruit dehulling machine with the design features of the blower above can be divided into four parts. According to [13], the power requirement can be expressed in equations below;

(I) Power Required to Drive Shaft

$$P_s = W_s \times r_s \tag{17}$$

Where;

W_s = weight of the shaft (N),

r_s = radius of shaft (m).

$$W_s = \text{mass} \times \text{force of gravity} \tag{18}$$

mass of the shaft = 6.00 kg

$$W_s = 6.00 \times 9.81 = 58.86 \text{ N}$$

$$r_s = \frac{D}{2} \tag{19}$$

$$r_s = \frac{D}{2} = \frac{0.08}{2} = 0.04 \text{ m}$$

$$P_s = 58.86 \times 0.04 = 2.354 \text{ W} \approx 0.002354 \text{ kW}$$

(II) Power Required to Dehull the African Breadfruit Seeds

$$P_d = \tau \times \omega \tag{20}$$

τ = Torque of the shaft (Nm)

ω = Angular speed of the shaft (m)

f = Total load on the shaft = 58.86 N

r_s = radius of shaft (m) = 0.04 m

$$\tau = f \times r_s \tag{21}$$

$$\omega = \frac{2\pi N}{60} \tag{22}$$

$$\tau = f \times r_s = 58.86 \times 0.04 = 2.35 \text{ Nm}$$

$$\omega = \frac{2 \times 3.142 \times 1500}{60} = 157.1 \text{ rad/sec}$$



$$P_d = 2.35 \times 157.1 = 369.88 \text{ W} = 0.3699 \text{ kW}$$

(III) Power Required to Drive the Pulley

$$P_p = W_p \times R_p \quad (23)$$

Where;

W_p = weight of the pulley (N),

R_p = radius of the pulley = 0.055 m

Mass of the pulley = 0.75 kg

$$W_p = mg \quad (24)$$

$$W_p = mg = 0.75 \text{ kg} \times 9.81 \text{ m/s}^2 = 7.36 \text{ N}$$

$$P_p = 7.36 \times 0.055 = 0.4047 \text{ kW}$$

(IV) Power Input of the Blower

According to [15], the power input of the blower, P_b which is also the same as the power required to drive the blower mechanism can be estimated as follows;

$$P_b = \rho Q g h \quad (25)$$

Whereas,

$$h = \frac{V_2^2}{2g} \quad (26)$$

$$= \frac{v_2^2}{2g} = \frac{74.4^2}{2 \times 9.81} = \frac{5535.36}{19.62} = 282.13 \text{ m}$$

Where,

ρ = Density of the Air (kg/m^3) = 1.239

Q = Fluid flow rate (m^3/s) = 0.744

g = Acceleration due to gravity = 9.81 m/s^2

h = total head change (m) = 282.13

$$P_b = 1.239 \times 0.744 \times 9.81 \times 282.13$$

$$= 1.239 \times 0.744 \times 9.81 \times 282.13$$

$$P_b = 2551.31 \text{ W} = 2.5513 \text{ kW}$$

Therefore, the total requirement of the dehuller can be estimated as follows;

$$\text{Total Power, } P_T = P_s + P_d + P_p + P_b \quad (27)$$

$$= 0.00235 \text{ kW} + 0.3699 \text{ kW} + 0.4047 \text{ kW} + 2.5513 \text{ kW} = 3.3283 \text{ kW}$$

$$P_T = 3.3283 \text{ kW} \approx 4.5 \text{ hp}$$

Hence, 5.5hp or 6hp gasoline engine can be used to power the machine.

6. Pulley Size Determination

According to [16], the size pulley used can be estimated as follows;

$$N_1 D_1 = N_2 D_2 \quad (28)$$

Where,

N_1 = speed of driven pulley (rpm) = 1200 rpm (speed required at dehulling unit)

N_2 = speed of driving unit (rpm) = 1500 rpm

D_1 = diameter of driven pulley (mm) = 110 mm

D_2 = diameter of driving pulley (mm) = ?

$$1200 \times 110 = 1500 \times D_2$$

$$D_2 = \frac{1200 \times 110}{1500} = 88 \text{ mm}$$

7. Belt Size Determination

Length of belt was calculated using [17] equation below;

$$L = 2C + 1.57(D_2 + D_1) + \frac{(D_2 - D_1)^2}{4C} \tag{29}$$

Where,

L= length of belt, mm

C = distance between the centre of driving and the pulleys = 420 mm

D₁ = 88 mm

D₂ = 110 mm

$$L = 2 \times 420 + 1.57(88 + 110) + \frac{(88 - 110)^2}{4 \times 420}$$

$$= 840 + 298.3 + \frac{(-22)^2}{1680} = 1134 + 0.28 = 1134.28 \text{ mm}$$

$$L \approx 1134.28 \text{ mm} \approx 114 \text{ cm}$$

Therefore, the V-belt of A-43 can be used which is the equivalent to size estimated.

ASSEMBLY OF THE COMPONENT PARTS

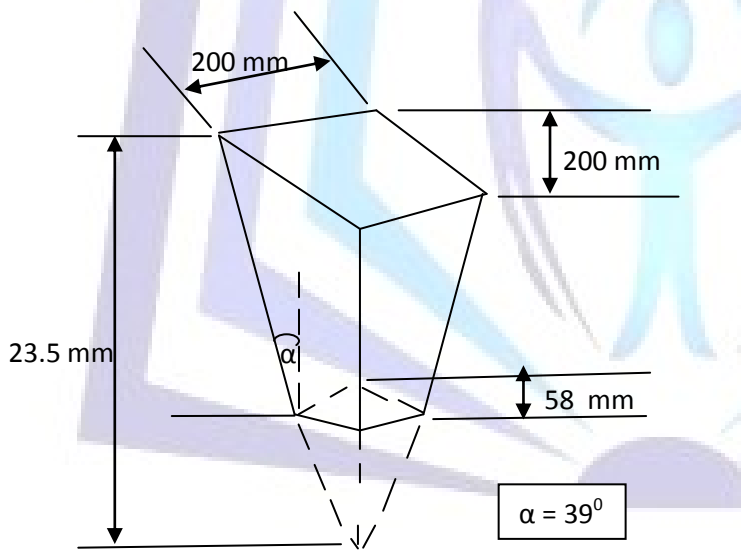

Fig. 5a: 2Dimensional Drawing of the Hopper

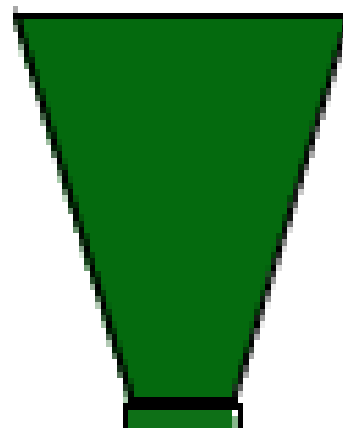

Fig. 5b: 3D Side View of the Hopper

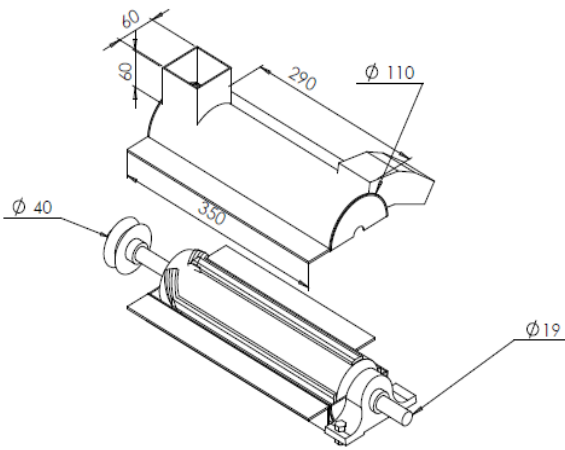

Fig. 6a: 2D Drawing of the Dehulling Chamber

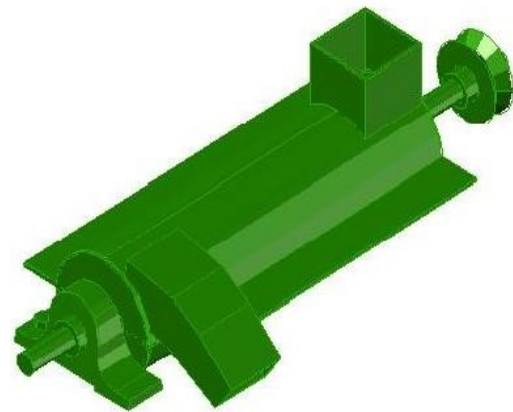

Fig.6b: 3D Drawing of the Dehulling Chamber

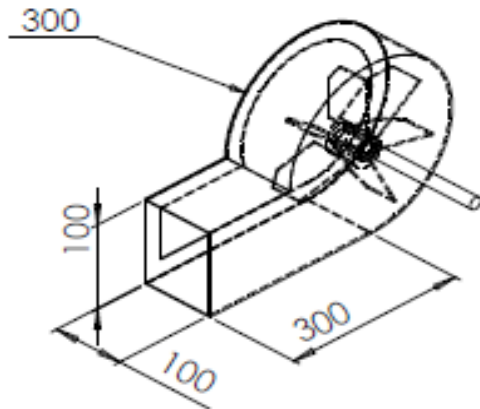

Fig. 7a: 2D Drawing of the Blower

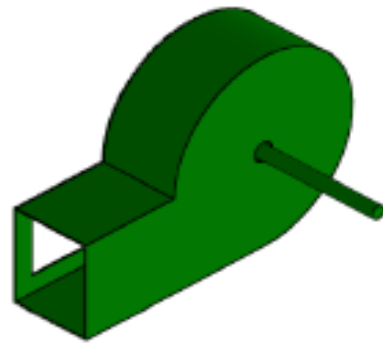

Fig. 7b: 3D Isometric View of the Blower

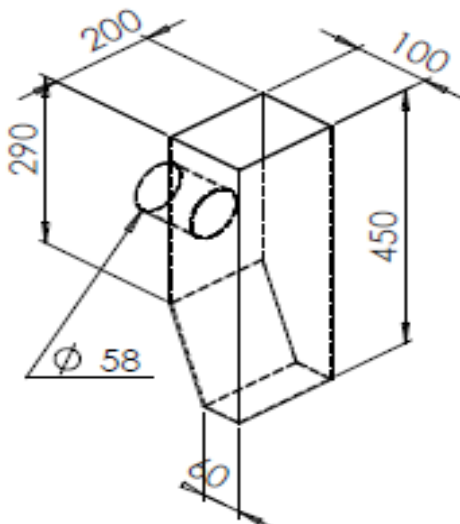

Fig. 8a: 2D of the 'Front' Discharge Chute

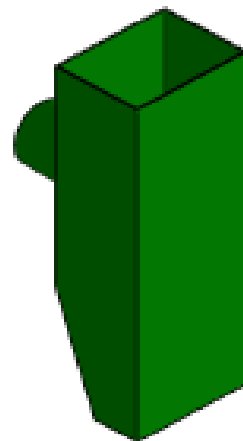

Fig. 8c: 3D 'Front' Discharge Chute

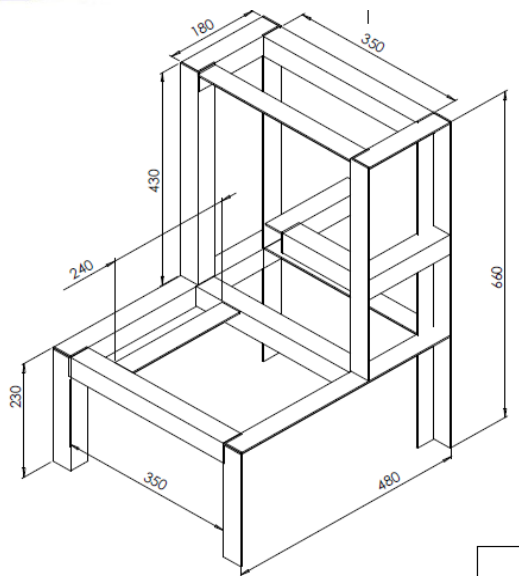

Fig. 9a: 2D Drawing of the Frame

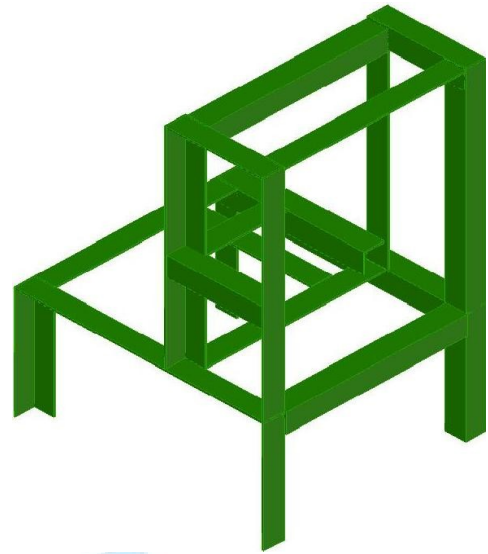

Fig. 9b: 3D Isometric View of the Frame

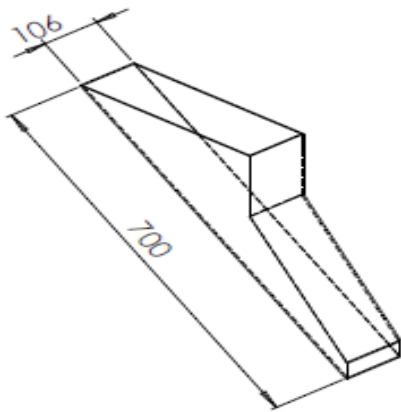

Fig. 10a: 2D of the 'Side' Discharge Chute

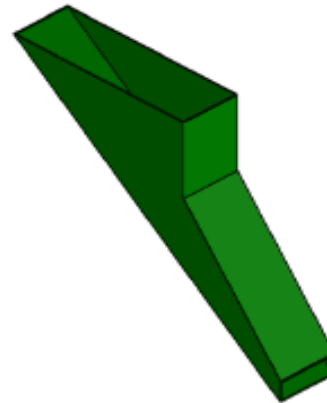

Fig. 10b: 3D of the 'Side' Discharge Chute

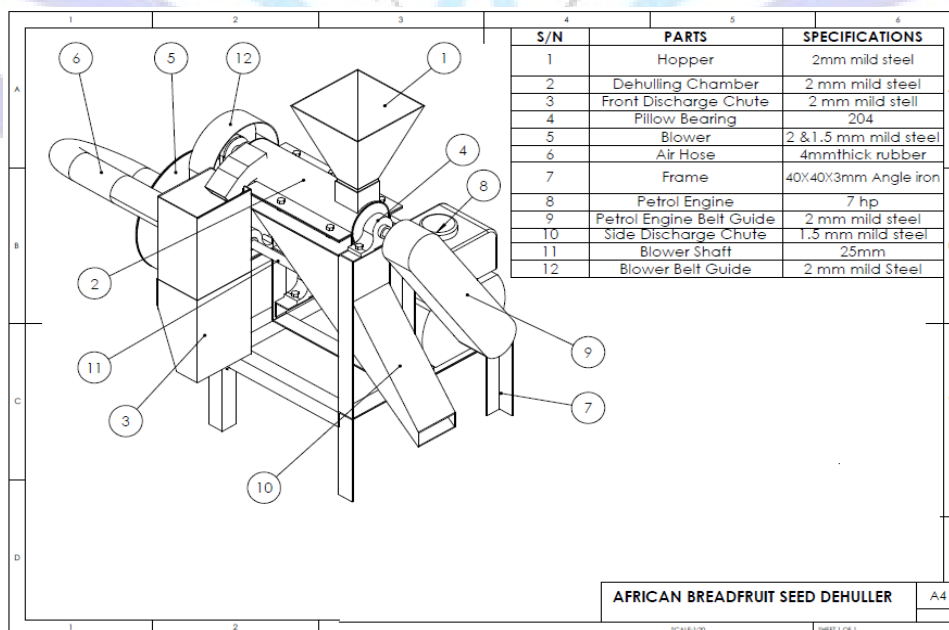

Fig. 11: 2D Isometric View of the Dehuller with Parts Description



CONCLUSION

The step by step method of designing and fabricating an African breadfruit seeds dehuller has been reviewed and outlined to help the fabricators simplify the design intricacies involved in the production of the dehuller. With this vital document, anyone who wants to go into the commercial production of African breadfruit dehuller can venture into that without fear. The idea is to provide a working document that will help student, researchers, and local fabricators to solve the problems of hard labour, time wasted and drudgery associated with manual means of the seed dehulling.

REFERENCES

- [1] Oguntola Sade 2013. African breadfruit: Nature's antidote to sleeplessness, hypertension. Accessed online on 25th April, 2015.
- [2] Okonkwo Ego U. and Ubani Ozioma N. 2012. Application of HACCP to Post-harvest Processing of African Breadfruit *Treculia Africana* Decne in Nigeria. African Journal of Agricultural Research Vol. 7(32), pp. 4536-4539, 21 August , 2012
- [3] Irvine J.I. 1981. Comparative Study of the Chemical Composition and Mineral Element Content of *Treculia africana* Seeds and Seed Oils. Journal of Food Engineering, 40:241-244.
- [4] Ugwoke F.N., Agbo A.E., Ali N.C., Attah C.P. and Ekwueme J.I. 2003. A Note on African Breadfruit (*Treculia africana* Decne). Unpublished Report Submitted in Partial Fulfillment of CSC 341, Dept. of Crop Science, University of Nigeria, Nsukka, Nigeria, p.18.
- [5] WAC (World Agroforestry Centre) 2004. *Treculia africana*. In: Agroforestry Database; <http://www.worldagroforestry.org/sea/products/afdbases/af/asp/speciesInfo.asp?SpID=1651>-Assessed on 2/12/2010.
- [6] Adumanya O.C., Akunna T.O., Onwusonye J.C, and Obi-Adumanya G.A. 2013. The Effects of Traditional Processing Methods on Mineral Contents of African Breadfruit (*Treculia Africana*) Seeds. International Research Journal 4(2):23-26, 2013.
- [7] Etoamaihe U.J and Ndubueze K.C. 2010. Development of and performance of a dehulling Machine African Breadfruit (*Treculia africana*). Journal of Engineering and Applied science 5(4); 312-315, 2010.
- [8] Amiebeomo S.O, Omorodion L.I and Igbesi F.C. 2013. Development of and Performance Evaluation of an African Breadfruit Shredder Machine. International Journal of Research and Technology, Vol. 2, Issue 3, March, 2013.
- [9] Richey, C.B; Jacobson P.A and Half C.W. 1961. Agricultural Engineering Handbook. McGraw-Hill, Book Co., Toronto, pp: 78 – 80.
- [10] Adgidzi, D. 2009. Development and Performance Evaluation of a Forage Chopper. J. Agric. Engin. Technol., 15:12 – 24.
- [11] Khurmi, R.S, Gupta, J.K. 2005. Machine Design. Eurasia Publishing House (PVT) Ltd, Nagar, New Delhi.
- [12] Shittu S.K., and Ndrika V.I.O. 2007. Development and performance tests of a melon (egusi) Seed shelling machine. Agric Eng Int: CIGR Journal, 14(1): Manuscript 2027.
- [13] Gbabo, A., Liberty, J.T and Fadele O.S. 2013. Design, Construction and Assessment of African Locust Bean (*Parkia biglobosa*) Dehuller and Seperator. *International Journal of Engineering and Innovative Technology (IJEIT)* Volume 3, Issue 5, November 2013.
- [14] Adejuyigbe, S.B and Bolaji, B.O. 2005. Design, Fabrication and Performance Evaluation of Beans Dehuller. Journal of Science and Technology, Vol 25, No 1.
- [15] Adekunle Taofeek Oyelami, Olawale Oluwadare Olaniyan, Dalyop Iliya and Abimbola Samson Idowu 2008. The Design of a Closed-Type-Impeller Blower for a 500kg Capacity Rotary Furnace. AU J.T. 12(1): 50-56 (Jul. 2008).
- [16] Aaron, D. 1975. Machine Design. In Theory and Practice. London, Collier Macmillan.
- [17] Khurmi, R.S. and Gupta J.K. 2004. Theory of Machines. New Delhi:Eurasia Publishing house.