

# THE PROSPECT OF SOLAR POWER GENERATION TECHNOLOGY

Ajaegbu C., Awodele O., Kuyoro S. O. and Omotunde A. A.

Department of Computer Science

Babcock University, Nigeria

## ABSTRACT

Over the years, several means of electrical power generation have been in place ranging from wood, coal, to fuel. All these means have at its point served purpose at the needed time. This work presents the historical research of solar power in space, an insight into some literature pertaining to Solar Power Satellite (SPS) and Wireless Power Transmission (WPT) and an insight into the working principle of solar power generation was presented. It was observed that despite the various prospects that were identified by the various researchers less attention was paid to the means of enhancing the range of transmission of solar power satellite.

**Keywords:** solar power satellite, wireless power transmission, space base solar power, fuel, prospects

## 1.0 INTRODUCTION

The most common challenge in the transmission of power is the losses that occur during transmission and distribution. As more power is being distributed, more energy is being lost as a result of the grid resistance. The generation of electricity started in the year 1882 in New York by Edison in his pearl street power station and the first major AC generator was opened by George Westinghouse at Niagara Falls in the year 1895.[1] The increase in population over the years has resulted in the need for energy substitute. As the world grows in population, more demands for energy rises and the need of the current energy supply might be worn out. This challenge leads to a knowledge search for energy substitute. The world's technological advancements have enhanced fast alternatives to the above mentioned challenges. Peter Glaser [2] proposed way of generating electricity on a 24-hour continuous basis using solar collectors in space where they can collect sunlight regularly [3]. The process by which sunlight can be used to generate electricity is known as solar power. Research has shown that this technology stands to be a prominent, natural and economical means of generating useful power. This work focus on the prospect of solar power generation as an alternative to other power generation means. It presents the historical research of solar power in space, insight into some literature pertaining to Solar Power Satellite (SPS) and Wireless Power Transmission (WPT) and insight into the working principle of solar power generation.

The remainder of this paper is organized as follows. Section 2 gives the historical progress of research works on both systems. Section 3 discusses previous related works. Section 4 looked at the working principle of solar power generation and transmission. Section 5 concludes the work and proposes future work.

## 2.0 HISTORICAL REVIEW

In 1904, an airship motor of 0.1 horsepower was driven by transmitting power through space from a distance of 100ft. Brown published a paper proposing microwave energy for power transmission in 1961 and came up with a microwave-

powered model helicopter that received all power need to fly from the microwave beam operating in the range of 2.45GHz in 1964. Peter Glaser introduced the concept of generating solar power from space in the year 1968 for human consumption. His idea caught the attention of researchers around the world over decades. In the late 1970's, the US Department of Energy and NASA conducted major Solar Power Satellites (SPS). The project was set to invest about \$250B in respect to the delivery of the first kilowatt-hour[3]. This project was discontinued around 1980 due to some major setbacks which the \$250B cost of the reference system was among.

Within the year 1976-1980 the US department of Energy (DOE) and NASA conducted major SPS research, the research centered mostly on developing an SPS system that is capable of delivering a kilo-watt-hour of energy. This project was discontinued in the late 1980 because of some pressing issues in US [Mankins,1997]. The world's first fuel free airplane powered by microwave energy from ground in Canada, SHARP (Stationary High – Altitude Relay Platform) was developed. In 2003, Dryden Flight Research Centre of NASA demonstrated a laser powered model airplane indoors. Japan proposed wireless charging of electric motor vehicles by Microwave Power Transmission in 2004. Powercast in central Tawain, introduced wireless power transfer technology using RF energy at Consumer Electronics Show in 2007 and in the same year, a physics research group, led by Prof. Marin Soljačić, at the Massachusetts Institute of technology (MIT) demonstrated wireless powering of a 60W light bulb with 40% efficiency at a 2m (7ft) distance using two 60cm-diameter coils. Recently in 2008, Intel reproduced the MIT group's experiment by wirelessly powering a light bulb with 75% efficiency at a shorter distance.

The prospects of SPS have been quite challenging over the year. It requires a lot of technical knowhow and manpower to ensure proper and efficient transmission of the power signal from the transmitting antenna to the receiving antenna and also the realization of DC power effectively (WPT technology).

## 3.0 RELATED WORKS

[1] looked at the generation of solar power using SPS and WPT. In their work, they pointed out one of the major problems of coal, oil and nuclear power generation means as running out of reach in the nearest future due to demand population increase and the urge to improve living standards by the underdeveloped nations. The lack of energy replenishment attached to the current energy sources was noted in their work as a challenge. The aim of the paper was to give a general overview of SPS; the concept of solar power satellites and the ground test program proposed by solar space industries and, also to look at the various advantages and disadvantages offers by SPS. A historical review of SPS development and insight of the two major forms through which the solar power can be transmitted, the use of

microwave system and Laser-based system was in cooperated to achieve the objectives. Though, some basic parameters were highlighted in their work such as space environment, the range and size of microwave beam which were attached to the Ground Test Program of SPS. Their work fails to relate the importance of the range and topology layout to the mentioned means of achieving wireless power generation through SPS.

[4] looked at the generation of power using Space Based Solar Power (SBSP) and its wireless transmission. In their work, SBSP is set to displace the fossil fuel, nuclear and biological sources of energy, elimination of transmission and overhead lines. The main aim of the work was to show the prospects of SBSP and this was accomplished through comparison of generation sources. It was observed that, there is a high tendency of the usual fossil fuel running out of place by year 2030 while SBSP will offer better lasting solution because of the sun's constant energy generation. However, the

authors failed to address the wireless power transmission system as a standalone system. Also, the cost of WPT system installation and the possible means of avoiding interference with other systems were not addressed in their paper.

[5] looked at wireless power transmission as the next generation power transmission system. In their paper, they noted one of the major problems attached with grid system which is the loss of power during transmission. They presented the means of achieving power transmission without the use of wire as shown in Figure 1. The authors explore some prospects of WPT, including some application areas and noted that WPT will offer better advantages over the use of wired power transmission. In their work, they pointed out one of the major challenge of WPT as likely interference of microwave with present communication system but failed to suggest possible remedy.

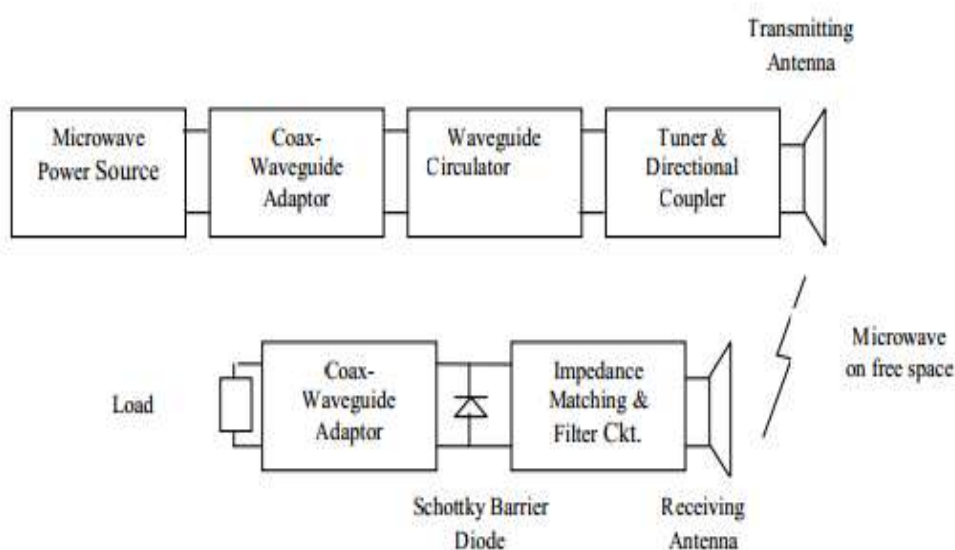

Figure 1: WPT system [3]

#### 4.0 THE WORKING PRINCIPLE OF SOLAR POWER GENERATION

The synergy of SPS and WPT involves the placement of giant satellites surrounded with vast arrays of solar cells in a Geo synchronous Orbit 22,000 to 26,000 miles away from the ground. Each satellite experiences the sun's light 24hrs of the day. It is only during the rainy seasons that the satellites are exposed to shadow. The working principle of the above mentioned system in electricity generation is such that the solar panel which is a collection of solar cells picks up the sun's energy and converts it to electricity with the help of its semiconductor component such as silicon. The electric signal

is then picked up by a transmitter which transforms it into a transmittable signal using radio frequency and this is accomplished by a transmitting antenna. The transmitted signal is received at the receiving end of the ground by a rectenna. A rectenna is a device that consists of the combination of an antenna and a Schottky diode. The combination of these two helps in converting the transmitted signal into a DC signal. The signal passes through further scrutiny using the power conditioner unit. This unit is made up of filters and impedance matching, which helps in putting the signal back to shape in case of distortions. The DC signal on getting to the earth station is inverted to an AC signal needed for the grid system serving individuals as shown in Figure 2.

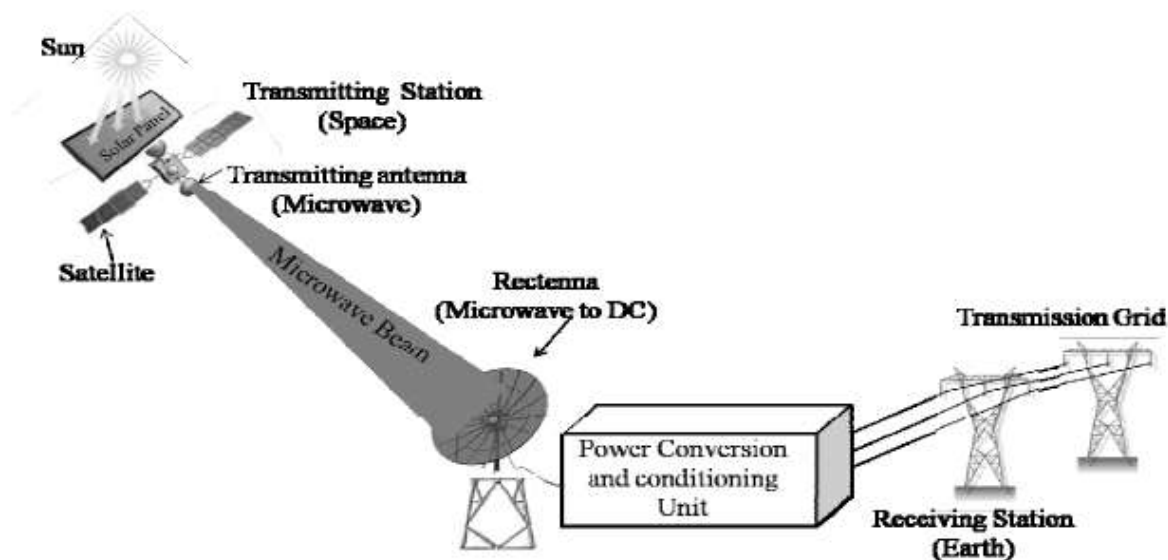

Figure 2: Solar Power System [1]

## 5.0 CONCLUSION AND RECOMMENDATION FOR FURTHER WORK

Though, WPT system along with SPBS offers some benefits such as improved means of power generation. Individuals will experience more steady power compared to what is available now. Among so many added advantages, there will be low tariff cost to consumers. Consumers will not need to involve so much before they can enjoy electricity. Another benefit is elimination of power overhead lines. The use of the above mentioned system will eliminate the use of overhead cables. It is of importance that due consideration be given to the distance of coverage since one of its major aim is to reach out to every home in terms of electricity. Also the effects of terrains should be given due consideration during the design and implementation of the hybrid power system. It is also of utmost importance that the operation of WPT using SBSP should be properly defined within a frequency range outside other communication systems. This will ensure greater efficiency and avoidance of interference with other wireless systems. This work has been able to discuss the prospect of solar power generation as an alternative to other power generation means, presenting the historical research of solar power in space and discussed the views of some researchers on Solar Power Satellite (SPS) and Wireless Power Transmission (WPT). It also gives an insight into the working principle of solar power generation.

In our future work, we intend to take a look at the effect of AMIS-49587 in the transmitting end using AMIS-49587, which is a power line carrier modem built around an ARM

[6] International Journal of Computer Applications. 1(13) 100-103.

[7] Jung K.H;Kim Y.H; Kim Y.J,(2009). Wireless power transmission for implantable devices using inductive component of closed magnetic circuit. Electronics Letters. 45(1).

7TDMI processor core. It is a complaint power line modem that uses Spread Frequency Shift Keying (S-FSK) modulation technique for enhancing a low data rate communication, over power lines. With its robust modulation technique; it allows signals on the power lines to travel over a long distance. The application of AMIS-49587 looks promising in terms of wider coverage and it is a research worth exploring.

## REFERENCES

- [1] Mohammed S.S & Ramasamy K (2009). Solar Power Generation using SPS and Wireless Power Transmission. Proceeding of international Conference on Energy and Environment. 413-418.
- [2] Glaser P (2006). Space and A Sustainable 21st Century Energy System. Retrieved on 29-10 2012 from [http://www.esa.int/gsp/ACT/doc/POW/ACT-RPR-NRG-2006-IAC-SPS-Peter\\_Glaser\\_Paper.pdf](http://www.esa.int/gsp/ACT/doc/POW/ACT-RPR-NRG-2006-IAC-SPS-Peter_Glaser_Paper.pdf)
- [3] Martins J C (1997), Space Solar Power: A Prospective Future Energy Source. <http://www.nss.org/settlement/manufacturing/SM12.155.SpaceSolarPowerProspectiveFutureEnergySource.pdf> Retrieved on 29/10/2012
- [4] Barathwaj G and Srinage K (2011). Wireless Power Transmission of Space Based Solar Power. IPCBEE 6(2011). 227-231.
- [5] Mohammed S and Ramasamy K (2010). Wireless Power Transmission- A Next generation Power Transmission System.
- [8] Ahmed S.S;Yeong T.W;Ahmad H.B (2003). Wireless power transmission and its annexure to the grid system. IEEE. 150(2) 195-199.
- [9] Murao Y & Takano T (2000). An Investigation on the Design of a Transmission Antenna and a Rectenna with Arrayed Apertures for Microwave Power Transmission. Electronic and Communications in Japan. 83(2) 46-53.