

Legend:

2R = 5200 mm  
 2r = 4800 mm  
 H = 7700 mm  
 h = 1000 mm

HA - manual activation  
 RC - remote control  
 AC - automatic control  
 CP - control panel

B - burner  
 P - bed layer  
 f-s - fluo seal  
 MT - measurement temperatures

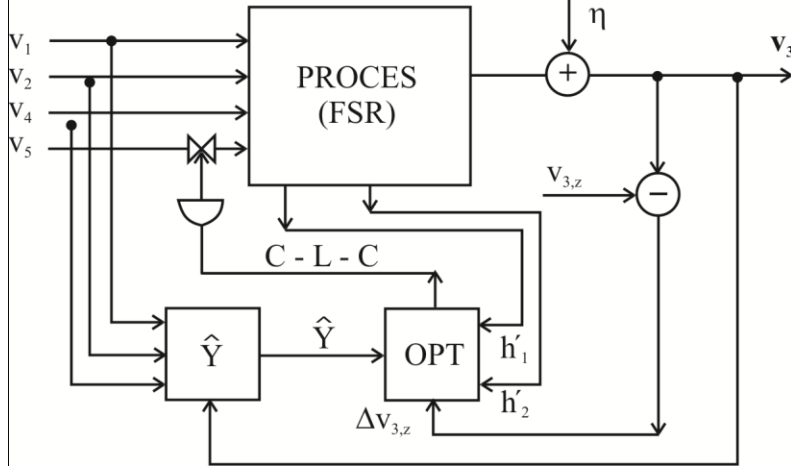
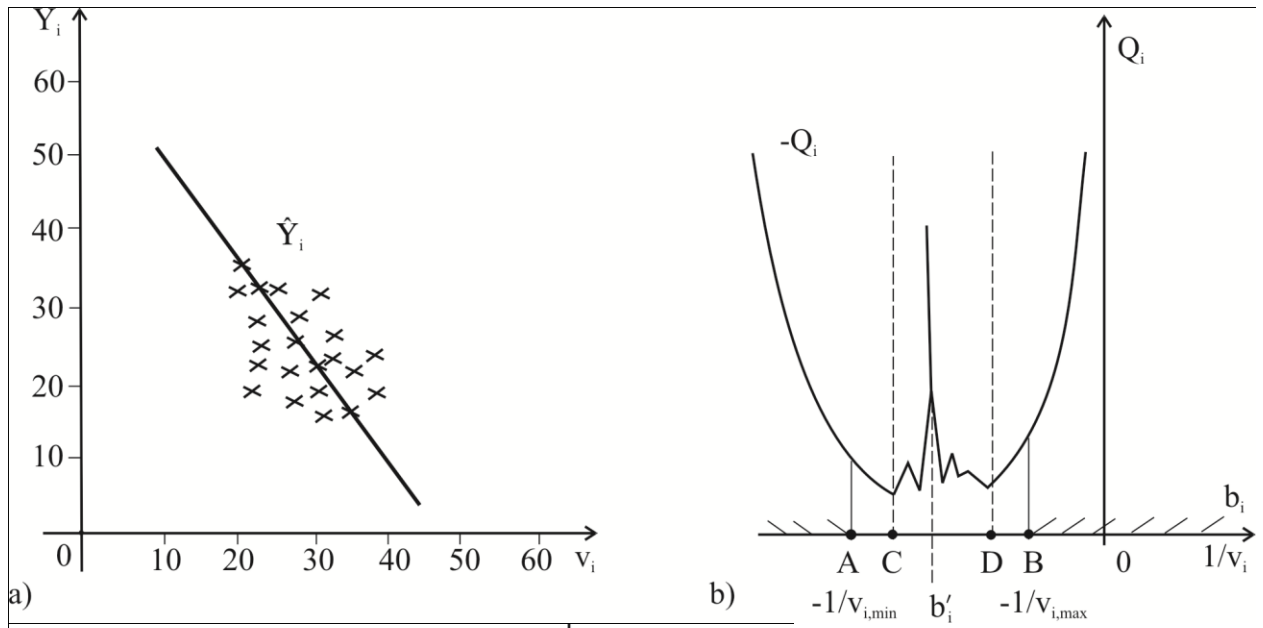

Legend:  
 OPT - Optimization block  
 C-L-C - Close Loop Control for hot air ( $v_3$ )  
 $h=(h_1, h_2)$  - constraints

